



# Articulated Robot Controller - GB Series

User Manual

Original Instruction





## Multi-Axis Robot

- Pick-and-place / Assembly / Array and packaging / Semiconductor / Electro-Optical industry / Automotive industry / Food industry
- Articulated Robot
  - Delta Robot
  - SCARA Robot
  - Wafer Robot
  - Electric Gripper
  - Integrated Electric Gripper
  - Rotary Joint



## Single-Axis Robot

- Precision / Semiconductor / Medical / FPD
- KK, SK
  - KS, KA
  - KU, KE, KC



## Direct Drive Rotary Table

- Aerospace / Medical / Automotive industry / Machine tools / Machinery industry
- RAB Series
  - RAS Series
  - RCV Series
  - RCH Series



## Ballscrew

- Precision Ground / Rolled
- Super S series
  - Super T series
  - Mini Roller
  - Ecological & Economical lubrication Module E2
  - Rotating Nut (R1)
  - Energy-Saving & Thermal-Controlling (C1)
  - Heavy Load Series (RD)
  - Ball Spline



## Linear Guideway

- Automation / Semiconductor / Medical
- Ball Type--HG, EG, WE, MG, CG
  - Quiet Type--QH, QE, QW, QR
  - Other--RG, E2, PG, SE, RC

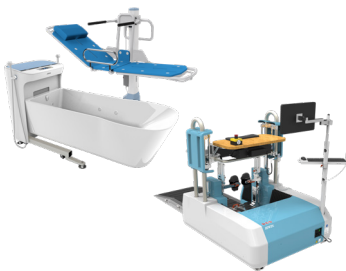

## Medical Equipment

- Hospital / Rehabilitation centers / Nursing homes
- Robotic Gait Training System
  - Hygiene System
  - Robotic Endoscope Holder



## Bearing

- Machine tools / Robot
- Crossed Roller Bearings
  - Ball Screw Bearings
  - Linear Bearing
  - Support Unit



## AC Servo Motor & Drive

- Semiconductor / Packaging machine / SMT / Food industry / LCD
- Drives-D1, D1-N, D2T
  - Motors-50W-2000W



## Driven Tool Holders

- All kinds of turret
- VDI Systems
  - Radial Series, Axial Series, MT
  - BMT Systems
  - DS, NM, GW, FO, MT, OM, MS

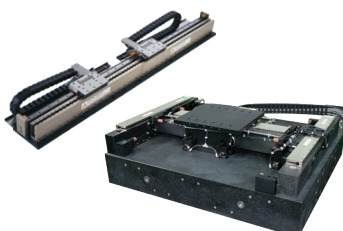

## Linear Motor

- Automated transport / AOI application / Precision / Semiconductor
- Iron-core Linear Motor
  - Coreless Linear Motor
  - Linear Turbo Motor LMT
  - Planar Servo Motor
  - Air Bearing Platform
  - X-Y Stage
  - Gantry Systems



## Torque Motor (Direct Drive Motor)

- Inspection / Testing equipment / Machine tools / Robot
- Rotary Tables-TMS,TMY,TMN
  - TMRW Series
  - TMRI Series

## Warranty Terms and Conditions

The period of warranty shall commence at the received date of HIWIN product (hereafter called “product”) and shall cover a period of 12 months. The warranty does not cover any of the damage and failure resulting from:

- The damage caused by using with the production line or the peripheral equipment not constructed by HIWIN.
- Operating method, environment and storage specifications not specifically recommended in the product manual.
- The damage caused by changing installation place, changing working environment, or improper transfer after being installed by the professional installer.
- Product or peripheral equipment damaged due to collision or accident caused by improper operation or installation by the unauthorized staff.
- Installing non-genuine HIWIN products.

The following conditions are not covered by the warranty:

- Product serial number or date of manufacture (month and year) cannot be verified.
- Using non-genuine HIWIN products.
- Adding or removing any components into/out the product without authorized.
- Any modification of the wiring and the cable of the product.
- Any modification of the appearance of the product; removal of the components inside the product. e.g., remove the outer cover, product drilling or cutting.
- Damage caused by any natural disaster. i.e., fire, earthquake, tsunami, lightning, windstorms and floods, tornado, typhoon, hurricane etc.

HIWIN does not provide any warranty or compensation to all the damage caused by above-mentioned circumstances unless the user can prove that the product is defective.

For more information towards warranty terms and conditions, please contact the technical staff or the dealer who you purchased with.



## WARNING

- ❖ Improper modification or disassemble the robot might reduce the robot function, stability or lifespan.
- ❖ The end-effector or the cable for devices should be installed and designed by a professional staff to avoid damaging the robot and robot malfunction.
- ❖ Please contact the technical staff for special modification coming from production line set up.
- ❖ For the safety reason, any modification for HIWIN product is strictly prohibited.

## Safety Precautions



### 1. Safety Information

- Safety Responsibility and Effect
  - ⊙ This chapter explains how to use the robot safely. Be sure to read this chapter carefully before using the robot.
  - ⊙ The user of the HIWIN industrial robot has responsibility to design and install the safety device meeting the industrial safety regulations in order to ensure personal safety.
  - ⊙ In compliance with the safety information on industrial robot described in this manual can't guarantee that *HIWIN* robot will not occur any safety problems.
  - ⊙ This machine is defined as a partly completed machinery, the associated hazards must be handled by system integrator in accordance with ISO 102018-1/-2.
  - ⊙ A safety-related part of control system (SRP/CS) should conform to the requirement of performance level d and category 3 according to ISO 13849-1.
  - ⊙ The installation for emergency functions shall be defined by the system integrator in accordance with ISO 10218-1/2.
- Safety Operation Principle
  - ⊙ Before connecting the power supply for HIWIN industrial robot startup assembly procedure, check whether the specification of factory output voltage matches the specification of input voltage of the product. If it does not match, ensure to use the corresponding transformer (HIWIN optional transformer is recommended).
  - ⊙ Emergency Stop button (on Teach Pendant or from external emergency stop switch) must be pressed before turning off the power, and then switch off the power switch.
  - ⊙ While connecting to the external I/O or the signal, please operate in the condition that the power switch is turned off to prevent from a shortcut caused by mistaken touch in the process, and resulting in damage.

## 2. Description Related to Safety

### I. Safety Symbols

- ⦿ Carefully read the instructions in the user manual prior to robot use. The following shows the safety symbols used in this user manual.

Symbol	Description
 <b>DANGER</b>	Failure to follow instructions with this symbol may result in serious hazard or personal injury. Please be sure to comply with these instructions.
 <b>WARNING</b>	Failure to follow instructions with this symbol may result in personal injury or product damage. Please be sure to comply with these instructions.
 <b>CAUTION</b>	Failure to follow instructions with this symbol may result in poor product performance. Please be sure to comply with these instructions.

### II. Working Person

- ⦿ The personnel can be classified as follows
  - Operator:
    - Turns robot controller ON/OFF
    - Starts robot program from operator's panel
    - Reset system alarm
  - Programmer or teaching operator:
    - Turns robot controller ON/OFF
    - Starts robot program from operator's panel
    - Reset system alarm
    - Teaches robot
  - Maintenance engineer:
    - Turns robot controller ON/OFF
    - Starts robot program from operator's panel
    - Reset system alarm
    - Teaches robot
    - Does maintenance, adjustment, replacement
- ⦿ Programmer and the maintenance engineer must be trained for proper robot operation.

### 3. Precautions

#### 3.1 Common Safety Issues

 <b>DANGER</b>	<ul style="list-style-type: none"> <li>❖ All operating procedures should be assessed by professional and in compliance with related industrial safety regulations.</li> <li>❖ When operating robot, operator needs to wear safety equipment, such as workwear for working environment, safety shoes and helmets.</li> <li>❖ When encountering danger or other emergency or abnormal situation, please press the emergency stop button immediately. After danger is eliminated, move the robot away with low speed in manual mode.</li> <li>❖ When considering safety of the robot, the robot and the system must be considered at the same time. Be sure to install safety fence or other safety equipment and the operator must stand outside the safety fence while operating the robot.</li> <li>❖ A safety zone should be established around the robot with an appropriate safety device to stop the unauthorized personnel from access.</li> <li>❖ While installing or removing mechanical components, be aware of a falling piece which may cause injury to operator.</li> <li>❖ Ensure the weight of workpiece does not exceed the rated load or allowable load moment at wrist. Exceeding these values could lead to the driver alarm or malfunction of the robot.</li> <li>❖ Do not climb on manipulator.</li> <li>❖ Do not store the machine in the environment with corrosion and flammable gas or close to the flammable object.</li> <li>❖ Do not operate the machine in the environment with moisture, water or grease.</li> <li>❖ Do not operate the machine at the place where vibration or the strong impact occurs.</li> <li>❖ Do not immerse the electric wires into grease or water.</li> </ul>
---	---

	<ul style="list-style-type: none"> <li>❖ Do not connect or operate the machine with wet hands.</li> <li>❖ Do not operate the machine in potentially explosive environment.</li> <li>❖ Please ensure the controller is grounded. Otherwise, unpredictable risks may occur.</li> <li>❖ Keep hands away from the inner part of the controller while it is connecting to the power or during operating.</li> <li>❖ Do not touch the heat sink, regenerative resistance, the power supply or the computer inside the controller while it is operating due to its high temperature.</li> <li>❖ Be sure power is disconnected prior to repair and maintenance, and ensure to operate under the condition of no electrical shock risk.</li> <li>❖ Do not disassembly the controller without permission. If there's any issues, please contact our engineers.</li> </ul>
<p> <b>WARNING</b></p>	<ul style="list-style-type: none"> <li>❖ The personnel installing robot should be trained and licensed.</li> <li>❖ To ensure personal safety, robot installation must comply with this manual and related industrial safety regulations.</li> <li>❖ The control cabinet should not be placed near high voltage or machines that generate electromagnetic fields to prevent interference that could cause the robot to deviation or malfunction.</li> <li>❖ Using non-HIWIN spare parts to repair may cause robot damage or malfunction.</li> <li>❖ Beware of the heat generated by the controller and servo motor.</li> <li>❖ Do not overbend the cable to avoid poor circuit contact or unexpected damage.</li> <li>❖ Do not stand on the controller or put heavy objects on it.</li> <li>❖ Do not block the vent or put foreign objects into the controller.</li> </ul>



	<ul style="list-style-type: none"><li>❖ Please ensure the controller is fixed on the base.</li><li>❖ Do not pull the connector violently or twist the electric wires excessively.</li><li>❖ Do not frequently switch ON/OFF the power switch and the control button.</li><li>❖ Please ensure that the robot, the emergency stop switch and the controller are functioning properly before performing any work.</li><li>❖ Do not shutdown the power switch during the operation.</li><li>❖ Do not open, modify, disassemble and maintain the machine without permission.</li><li>❖ The power must be disconnected when the machine does not operate in a long time.</li><li>❖ Do not turn off the power of the controller when modifying the program or parameter. Otherwise, the data stored in the controller will be damaged.</li><li>❖ After the brake of a servo motor is released, the robot will be moved due to gravity and it may injured the operator.</li><li>❖ The industrial robots can be applied for the different industrial environments.</li><li>❖ When the operating procedures are interrupted, the special attention should be paid during the troubleshooting.</li></ul>
--	---

### 3.2 Operation

 <p><b>DANGER</b></p>	<ul style="list-style-type: none"> <li>❖ Teaching, jogging or programming should be done outside of the safety fence. If it is inevitable to enter the safety fence, press the emergency stop button before entrance. Operation should be restricted at low speed and beware of surrounding safety.</li> <li>❖ All operations shall be executed by trained staff.</li> </ul>
--	--



### 3.3 Maintenance

 <p><b>DANGER</b></p>	<ul style="list-style-type: none"> <li>❖ Please contact us if the procedure not specified by HIWIN is needed.</li> <li>❖ Please contact us if the replacement of the component not specified by HIWIN is needed.</li> <li>❖ Be sure to carry out regular maintenance, otherwise it will affect the service life of the robot or other unexpected danger.</li> <li>❖ Prior to repair and maintenance, please switch off power supply.</li> <li>❖ Maintenance and repair should be performed by a qualified operator with a complete understanding of the entire system to avoid risk of robot damage and personal injury.</li> <li>❖ When replacing the components, avoid foreign object going into the robot.</li> </ul>
---	--



### 3.4 End Effector

The end effector can be classified as two types:

- A. Gripper: Used to load and unload, such as pneumatic gripper, electric gripper and vacuum sucker.
- B. Tool: Used to process, such as welding, cutting and surface treatment.



 <p><b>DANGER</b></p>	<ul style="list-style-type: none"> <li>❖ More attention must be paid to the design of the end effector to prevent power loss or any other errors that could lead to workpiece falling or damage.</li> <li>❖ The tool-type end effector is usually equipped with high voltage, high temperature and active rotary shaft. Special attention should be paid to the operating safety.</li> <li>❖ The end effector should be mounted firmly on the robot to avoid workpiece fall during operation which may cause personal injury or hazard.</li> </ul>
 <p><b>WARNING</b></p>	<ul style="list-style-type: none"> <li>❖ The end effector may be equipped with its own control unit. During installation, pay attention to installed location. Ensure that the control unit does not interfere with robot operation.</li> <li>❖ The gripper-type end effector should prevent the workpiece from dropping or damaging when the robot experiences a power error or other errors. If potential dangers or abnormal situations exist when using end effector, the associated hazards must be handled by the system integrator in accordance with the related standards.</li> </ul>

### 3.5 Pneumatic, Hydraulic System

 <p><b>DANGER</b></p>	<ul style="list-style-type: none"> <li>❖ When using the pneumatic or hydraulic system, the gripped workpiece may fall due to insufficient pressure or gravity.</li> <li>❖ The pneumatic or hydraulic system must be equipped with the relief valve, so that it can be applied in an emergency.</li> </ul>
 <p><b>WARNING</b></p>	<ul style="list-style-type: none"> <li>❖ More attention should be paid to the pressure remained in the pneumatic systems after the power is disconnected.</li> </ul>

	<ul style="list-style-type: none"> <li>❖ The internal pressure must be released before the pneumatic systems are maintained.</li> <li>❖ More attention should be paid to the pressure in the pneumatic system as it is several times more than the atmosphere pressure.</li> </ul>
--	--

### 3.6 Emergency Stop Switch

 <p><b>DANGER</b></p>	<ul style="list-style-type: none"> <li>❖ The robot or other control component should have at least one device for immediate halt, such as an emergency stop switch.</li> <li>❖ The emergency stop button must be installed in an easily accessible location for quick stop.</li> <li>❖ While executing an emergency stop, power to the servo motor will be cut, and all movements will be stopped. And the control system will be shut down. Emergency stop should be reset if the restoration of operating procedure is wanted.</li> <li>❖ Avoid using emergency stop to replace a normal stop procedure. This could reduce the lifespan of the robot.</li> </ul>
 <p><b>WARNING</b></p>	<ul style="list-style-type: none"> <li>❖ The drive power and the control system will be disconnected to stop all actions during the emergency stop.</li> <li>❖ If you want to restart the procedures, you should reset the emergency stop switch.</li> <li>❖ Emergency stop established an immediate stop: Immediately stop the robot system, and disconnect the driver power.</li> <li>❖ The emergency stop switch is used for emergency stop only.</li> <li>❖ The <i>HIWIN</i> robot is equipped with two emergency stop switches, where one is installed on the teach pendant and the other is directly connected to the controller via a cable. If additional emergency stop switches are required, other connecting method can be applied for the same purpose.</li> <li>❖ Based on the relevant industrial safety regulations, the emergency stop switch is directly connected to the controller of the robot via the physical wires.</li> </ul>

	<p>❖ If the version of the braking is not applied to the whole axis, once the emergency stop is executed and the heavy objects are loaded on the robot end, the axis without brake will move due to gravity. This attention must be paid for safety issue.</p>
--	--

#### 4. Intended use

HIWIN robots are industrial robots and intended for pick-and-place, handling, assembling, deburring, grinding and polishing. Use is only permitted under the specified environment, for more detailed information please see section 2.5 environmental conditions.

Use is not permitted under the following conditions:

- Use in potentially explosive environments
- Use without performing risk assessments
- Transportation of people and animals
- Operation outside the allowed operating parameters

#### 5. Disposal

The disposal of HIWIN robot shall be in accordance with the local environmental regulations.

## Content

<b>1. Specification</b> .....	15
1.1 Standard Specification .....	15
1.2 Description of Model Name.....	18
1.3 Standard and Optional Equipment .....	19
1.4 Appearance Dimensions .....	23
1.5 Appearance Component.....	25
1.6 Operating Environment.....	26
1.7 Sticker and Label .....	27
<b>2. Installation</b> .....	29
2.1 Installation Dimensions .....	29
2.2 Multifunctional Installation Frame .....	31
2.3 Overview of industrial robot.....	33
2.4 Controller Boot/Shutdown Program Description.....	37
2.5 Power & Signal Cable Connection (CN2).....	42
2.6 Emergency Stop Switch Connection (CN3) .....	43
<b>3. External Input / Output</b> .....	45
3.1 Function I/O .....	46
3.2 Digital I/O .....	47
3.3 Example of Connection.....	48
3.4 RCA605 、610 External I/O Expansion Module .....	54
3.5 RCD403 Encoder Capture Module (CN5).....	58
3.6 RS-232 Port.....	61
<b>4. Teach Pendant</b> .....	63
<b>5. Maintenance</b> .....	65
5.1 UPS Battery (Only For Non-CE Version).....	65
5.2 Fan Cotton Filter .....	67
5.3 Fuse .....	68

**Version Update**

<b>Edition</b>	<b>Date</b>	<b>Applicable Range</b>	<b>Remark</b>
1.0.0	2018.08.15	GB Series	Preliminary edition
1.0.1	2018.09.17	GB Series	Modified UPS battery maintenance chapter Modified encoder capture module chapter
1.0.2	2018.11.01	GB Series	Modified encoder capture module chapter. Image of actual wiring example.

# 1. Specification

## 1.1 Standard Specification

The following table shows the standard specifications of 605 series robot controller.

Item		HIWIN Robot Controller		
Model No.		RCA605-710-GB	RCT605-710-GB	RCT605-909-GB
Optional with CE certification		Yes	N/A	N/A
Controlled Manipulator		RA605-710-GB	RT605-710-GB	RT605-909-GB
Positioning control		PTP(point-to-point) CP(continuous path)		
Joint control		AC servo control		
Operating system		HRSS		
Memory capacity	Fixed point	5000		
	Step number	10000		
Teaching method		Teach pendant		
Communication interface	RS232	1		
	Ethernet	2		
	USB	2		
External I/O	Emergency stop input	Input : 1		
	Function I/O	Input : 8	Output : 8	
	Digital I/O	Input : 24	Output : 24	
Power	Input power range (VAC)	Single-phase 200-240		
	Power capacity (KVA)	2		
	Power frequency (Hz)	50/60		
	Voltage drop (msec)	10 or less		
	Rating output current (A)	8		
	Current leakage (mA)	100		
Weight (kg)		34		
IP grade		20		
Temperature range for workplaces (°C)		0-45		
Relative humidity for workplaces (%RH)		20-75 (non-condensing)		
Storage temperature range (°C)		0~55		
Storage relative humidity (%RH)		20-75 (non-condensing)		
Grounding		Below100Ω		



The following table shows the standard specifications of 610 series robot controller.

Item		HIWIN Robot Controller						
Model No.	RCA610 0 -1355 -GB	RCA610 -1476 -GB	RCA610 0 -1672 -GB	RCA610 0 -1869 -GB	RCT610 0 -1355 -GB	RCT610 0 -1476 -GB	RCT610 0 -1672 -GB	RCT610 0 -1869 -GB
Controlled Manipulator	RA610 -1355 -GB	RA610 -1476 -GB	RA610 -1672 -GB	RA610 -1869 -GB	RT610 -1355 -GB	RT610 -1476 -GB	RT610 -1672 -GB	RT610 -1869 -GB
Positioning control	PTP(point-to-point) CP(continuous path)							
Joint control	AC servo control							
Operating system	HRSS							
Memory capacity	Fixed point	5000						
	Step number	10000						
Teaching method	Teach pendant							
Communication interface	RS232	1						
	Ethernet	2						
	USB	2						
External I/O	Emergency stop input	Input : 1						
	Function I/O	Input : 8      Output : 8						
	Digital I/O	Input : 24      Output : 24						
Power	Input power range (VAC)	Single-phase 200-240						
	Power capacity (KVA)	4						
	Power frequency (Hz)	50/60						
	Voltage drop (msec)	10 or less						
	Rating output current (A)	18						
	Current leakage (mA)	30						
Weight (kg)	43							
IP grade	20							
Temperature range for workplaces (°C)	0-45							
Relative humidity for workplaces (%RH)	20-75 (non-condensing)							
Storage temperature range (°C)	0~55							
Storage relative humidity (%RH)	20-75 (non-condensing)							
Grounding	Below100Ω							

The following table shows the standard specifications of 403 series robot controller.

Item		HIWIN Robot Controller	
Model No.		RCD403-1100-GB	RCD403-1100-PR-GB
Optional with CE certification		Yes	N/A
Controlled Manipulator		RD403-1100-GB	RD403-1100-PR-GB
Positioning control		PTP(point-to-point) CP(continuous path)	
Joint control		AC servo control	
Operating system		HRSS	
Memory capacity	Fixed point	5000	
	Step number	10000	
Teaching method		Teach pendant	
Communication interface	RS232	1	
	Ethernet	2	
	USB	2	
External I/O	Emergency stop input	Input : 1	
	Function I/O	Input : 8	Output : 8
	Digital I/O	Input : 24	Output : 24
	Encoder capture module	4 Channel	
Power	Input power range (VAC)	Three-phase AC 200-240	
	Power capacity (KVA)	1.5	
	Power frequency (Hz)	50/60	
	Voltage drop (msec)	10 or less	
	Rating output current (A)	4.5	
	Current leakage (mA)	30	
Weight (kg)		34	
IP grade		20	
Temperature range for workplaces (°C)		0-45	
Relative humidity for workplaces (%RH)		20-75 (non-condensing)	
Storage temperature range (°C)		0~55	
Storage relative humidity (%RH)		20-75 (non-condensing)	
Grounding		Below100Ω	

## 1.2 Description of Model Name

### Model

Model example

**RCA605– 710 – (CE)– GB**

				<b>Identification Code</b>
			GB	Version
				<b>Certification Code</b>
		CE		With CE version
		N/A		Non-CE version
				<b>Maximum Reach Radius</b>
	710			710 mm
	909			909 mm
	1100			1100 mm
	1100-PR			1100 mm (Note 1)
	1355			1355 mm
	1476			1476 mm
	1672			1672 mm
	1869			1869 mm
				<b>Series</b>
RCA605				RCA605 Series articulated robot controller
RCT605				RCT605 Series articulated robot controller
RCA610				RCA610 Series articulated robot controller
RCT610				RCT610 Series articulated robot controller
RCD403				RCD403 Series articulated robot controller

Note 1: PR non-food grade

### 1.3 Standard and Optional Equipment

Standard and optional equipment for 605 series robot controller.

Item	HIWIN Part No.	Standard	Optional	Remark
CN1, Main Power Cable	4C7011Z2	●	○	Refer to CH 2.3
CN2, Power Signal Cable 3M	AH301L01	●	○	Refer to CH 2.5
CN2, Power Signal Cable 5M	AH302701		○	Refer to CH 2.5
CN2, Power Signal Cable 10M	AH303901		○	Refer to CH 2.5
Connector Accessory Kit	4C201701	●	○	Refer to table 1
Fuse Accessory Kit	4C2024P1	●	○	Refer to table 2
Teach Pendant	AH302801		○	Refer to CH 4
CN3 Emergency Stop Switch Unit 5M	4C7013F3		○	Refer to CH 2.6
D-Sub Connector Wiring Set 37P(6M)	4C201DY1		○	Refer to table 3
External I/O Extension Module (Include expansion card and wiring set) (Note 1)	4C201DZ2		○	Refer to CH 3.4
Cotton Filter	4657003Y		○	Refer to CH 5.2
UPS battery (For Non-CE version)	462C0097		○	Refer to CH 5.1
Padlock Accessories (For CE version only)	462301D0		○	Refer to CH 2.4

\*Note 1:

Maximum Expansion:

16 Input and 16 Output (Optional)

Table 1: Connector accessory kit item content:

Item	HIWIN Part No.	Quantity
D-Sub Connector 15P	461800ZZ	1
Housing of D-Sub Connector 15P	4618010B	1
D-Sub Connector 37P	46180107	2
Housing of D-Sub Connector 37P	4618010D	2

Table 2: Fuse accessory kit item content:

Item	HIWIN Part No.	Quantity
Fuse 15A(Fuse1~3)	46210037	3
Fuse 5A(Fuse4)	46210053	2
Fuse 2A(Fuse5)	46210052	2

Table 3: D-Sub connector wiring set 37P item content:

Item	HIWIN Part No.	Quantity
Signal Relay Module	461100RE	2
D-Sub Connector Cable (6M)	460900TU	2

Standard and optional equipment for 610 series robot controller.

Item	HIWIN Part No.	Standard	Optional	Remark
CN1, Main Power Cable	4C7011Z2	●	○	Refer to CH 2.3
CN2, Power Signal Cable 5M	AH301W01	●	○	Refer to CH 2.5
CN2, Power Signal Cable 3M	AH301H01		○	Refer to CH 2.5
Connector Accessory Kit	4C201701	●	○	Refer to table 1
Fuse Accessory Kit	4C2024P1	●	○	Refer to table 2
Teach Pendant	AH302801		○	Refer to CH 4
CN3 Emergency Stop Switch Unit 5M	4C7013F3		○	Refer to CH 2.6
D-Sub Connector Wiring Set 37P(6M)	4C201DY1		○	Refer to table 3
External I/O Extension Module (Include expansion card and wiring set) (Note 1)	4C201DZ2		○	Refer to CH 3.4
Cotton Filter	4657003Y		○	Refer to CH 5.2
UPS battery	462C0097		○	Refer to CH 5.1

\*Note 1:

Maximum Expansion:

16 Input and 16 Output (Optional)

Table 1: Connector accessory kit item content:

Item	HIWIN Part No.	Quantity
D-Sub Connector 15P	461800ZZ	1
Housing of D-Sub Connector 15P	4618010B	1
D-Sub Connector 37P	46180107	2
Housing of D-Sub Connector 37P	4618010D	2

Table 2: Fuse accessory kit item content:

Item	HIWIN Part No.	Quantity
Fuse 15A(Fuse1~3)	46210037	3
Fuse 5A(Fuse4)	46210053	2
Fuse 2A(Fuse5)	46210052	2

Table 3: D-Sub connector wiring set 37P item content:

Item	HIWIN Part No.	Quantity
Signal Relay Module	461100RE	2
D-Sub Connector Cable (6M)	460900TU	2

Standard and optional equipment for 403 series robot controller.

Item	HIWIN Part No.	Standard	Optional	Remark
CN1, Main Power Cable	4C7018Y1	●	○	Refer to CH 2.3
CN2, Power Signal Cable 5M	AH301A01	●	○	Refer to CH 2.5
CN2, Power Signal Cable 10M	AH303401		○	Refer to CH 2.5
Connector Accessory Kit	4C201M91	●	○	Refer to table 1
Fuse Accessory Kit	4C2024P1	●	○	Refer to table 2
Teach Pendant	AH302801		○	Refer to CH 4
CN3 Emergency Stop Switch Unit 5M	4C7013F3		○	Refer to CH 2.6
D-Sub Connector Wiring Set 37P(6M)	4C201DY1		○	Refer to table 3
D-Sub Connector Wiring Set 37P(10M)	4C201SN1		○	Refer to table 4
Conveyer Tracking Encoder	462B00C7		○	Refer to CH 3
Cotton Filter	4657003Y		○	Refer to CH 5.2
UPS battery (For Non-CE version)	462C0097		○	Refer to CH 5.1
Padlock Accessories (For CE version only)	462301D0		○	Refer to CH 2.4
Transformer Power Cable	4C704YW1		○	Refer to CH 2.3
2KVA Transformer	462D0049		○	Refer to CH 2.3
2KVA Transformer, Box(Note 1)	462D0047		○	Refer to CH 2.3
2KVA Transformer, Box, UL version(Note 1)	462D0048		○	Refer to CH 2.3

\*Note 1: The above transformers are all I/P380V-415V-480V-575V, O/P220V

Table 1: Connector accessory kit item content:

Item	HIWIN Part No.	Quantity
D-Sub Connector 15P	461800ZZ	1
Housing of D-Sub Connector 15P	4618010B	1
D-Sub Connector 37P	46180107	3
Housing of D-Sub Connector 37P	4618010D	3

Table 2: Fuse accessory kit item content:

Item	HIWIN Part No.	Quantity
Fuse 15A(Fuse1~3)	46210037	3
Fuse 5A(Fuse4)	46210053	2
Fuse 2A(Fuse5)	46210052	2

Table 3: D-Sub connector wiring set 37P (6M) item content:

Item	HIWIN Part No.	Quantity
Signal Relay Module (6M)	461100RE	2
D-Sub Connector Cable (6M)	460900TU	2

Table 4: D-Sub connector wiring set 37P (10M) item content:

Item	HIWIN Part No.	Quantity
Signal Relay Module (10M)	461100RE	1
D-Sub Connector Cable (10M)	460900YD	1

## 1.4 Appearance Dimensions

The following below shows appearance dimensions of 605 , 403 series robot controller. (unit: mm)

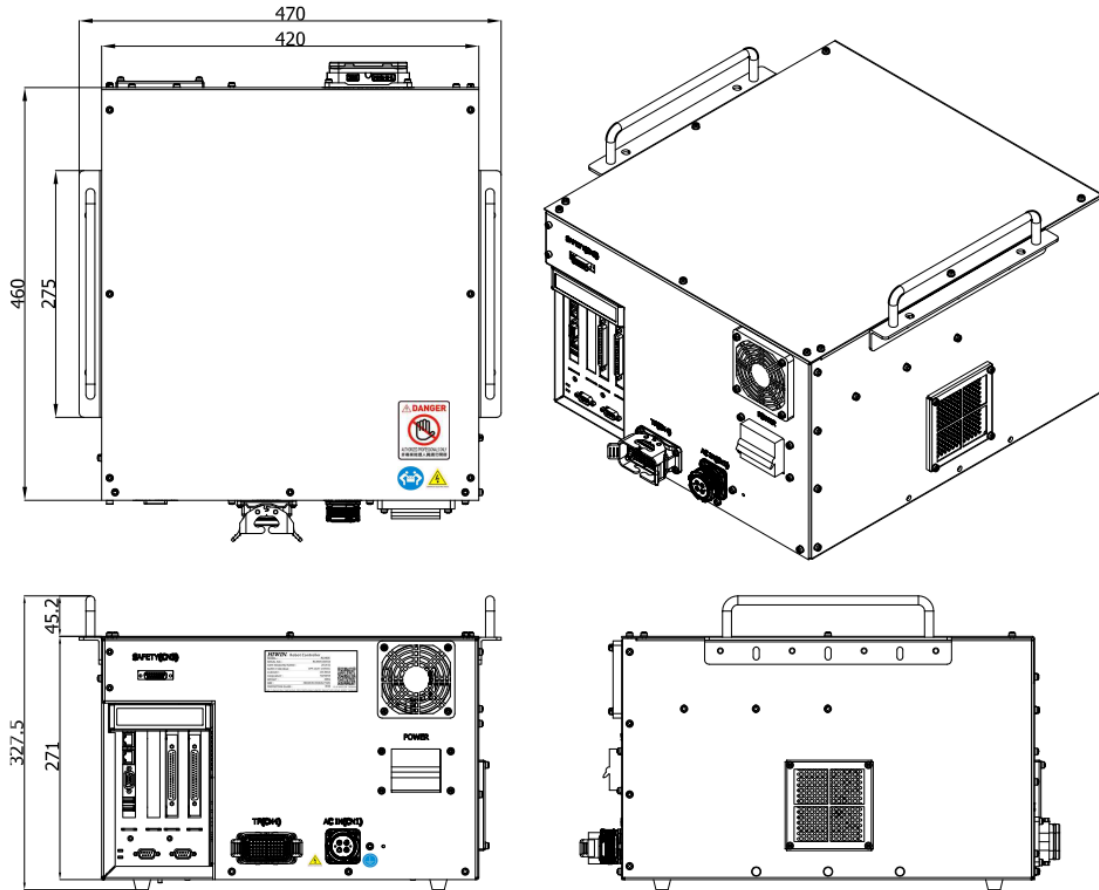

### CAUTION

- ❖ As a complete installation dimension, some space needs to be reserved for the cables. Please refer to CH2.1.



The following below show appearance dimensions of 610 series robot controller.  
(unit: mm)

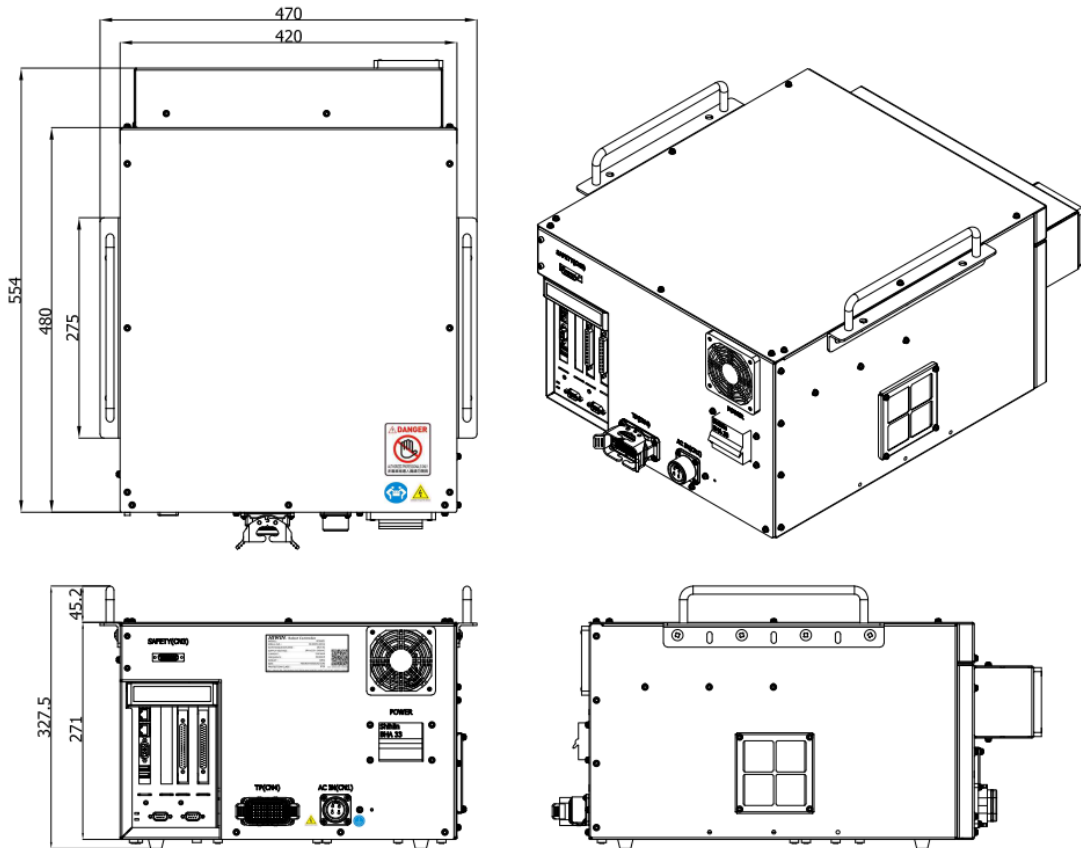

**CAUTION**

- ❖ As a complete installation dimension, some space needs to be reserved for the cables. Please refer to CH2.1.

## 1.5 Appearance Component

The function of each connector outside the GB series robot controller.

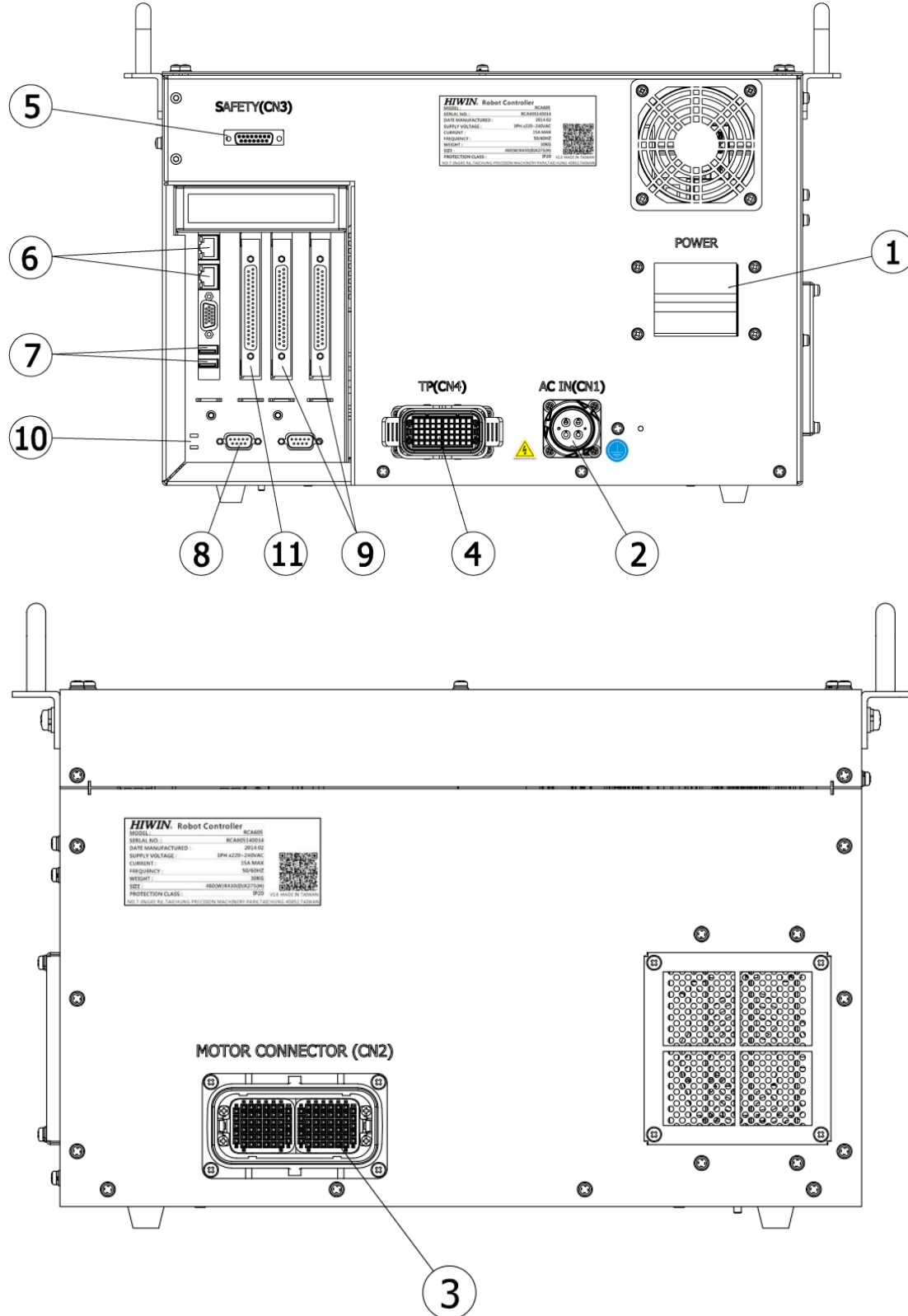

No.	Item	Description
1	Power Switch	Switch power ON/OFF
2	Main Power Source	Inlet single phase AC220V
3	Power & Signal Connector(CN2)	Connect robot controller to the robot manipulator
4	Teach Pendant Connector(CN4)	Connect to teach pendant
5	Emergency Stop Connector(CN3)	Connect to external emergency stop device
6	Network Connector	Connect to Ethernet device
7	USB Connector	Connect to USB device
8	RS232 Connector	Connect to RS232 device
9	I/O Connector	Connect to I/O device
10	Controller Power Indicator Green Light	Display ON/OFF status
11	Encoder Connector	Connect to encoder device (403 series standard & optional)

## 1.6 Operating Environment

The robot controller employs the IEC protection rating as IP20 (open). In addition, IP20 indicates the protection rating for the solid, not for grease and water.



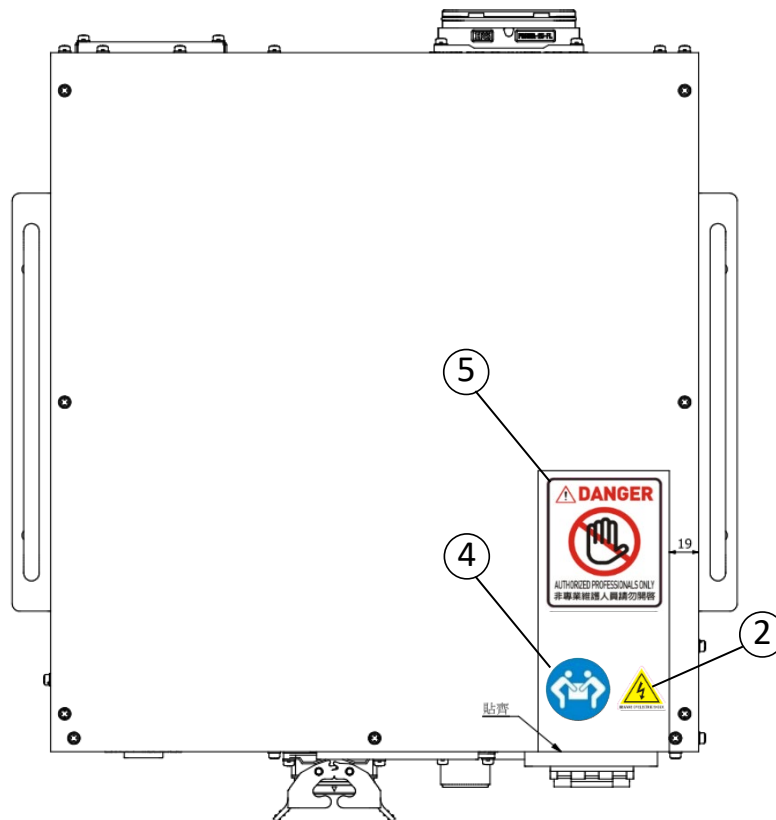
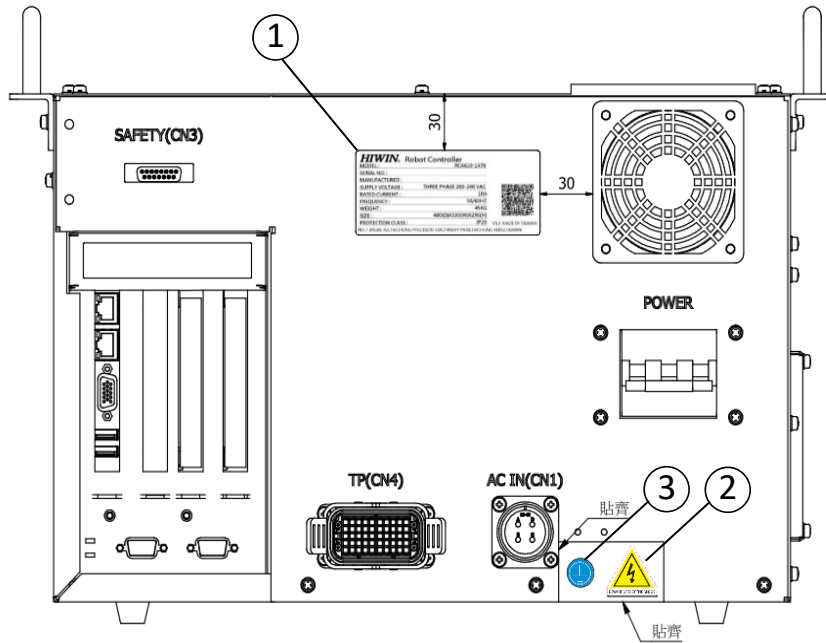

 <b>WARNING</b>	<ul style="list-style-type: none"> <li>❖ The controller should not be placed at the environment with moisture, with high temperature, under direct sunlight or potentially explosive environment.</li> <li>❖ Please keep the controller away from the strong electric field or the magnetic field.</li> <li>❖ Because the vents are set on the right side of the controller, please ensure a space 50mm from the right.</li> <li>❖ Please place the controller at flat place, and avoid shaking.</li> </ul>
---	---

## 1.7 Sticker and Label

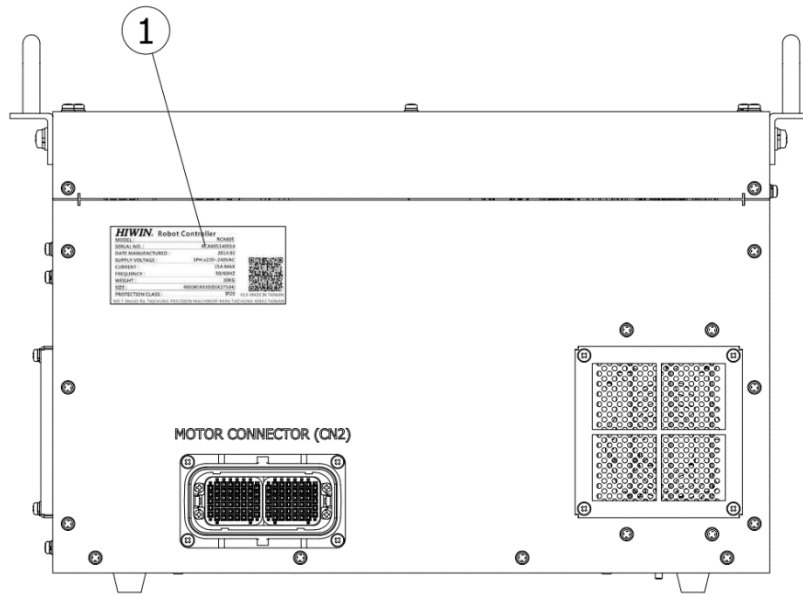
The following shows the appearance stickers and labels of GB series robot controller.





No.	Illustration	Description
1	<p><b>HIWIN</b> Robot Controller MODEL: RCA610-1476 SERIAL NO.: MANUFACTURED: SUPPLY VOLTAGE: THREE PHASE 200-240 VAC RATED CURRENT: 10A FREQUENCY: 50/60HZ WEIGHT: 45KG SIZE: 480(D)X530(W)X290(H) PROTECTION CLASS: IP20</p> <p>NO.7 JINGKE RG, TAICHUNG PRECISION MACHINERY PARK, TAICHUNG 40852, TAIWAN V1.6 MADE IN TAIWAN</p> 	Controller specification
2	 <p>BEWARE OF ELECTRIC SHOCK</p>	Beware of electric shock
3		Grounding
4		Transport by multiple people
5	 <p><b>DANGER</b></p> <p>AUTHORIZED PROFESSIONALS ONLY 非專業維護人員請勿開啓</p>	Danger: authorized professionals only

## 2. Installation

### 2.1 Installation Dimensions

The following shows the 605 and 403 series robot controller connector installation space. Please reserve some space for the connecting wires to avoid interference as they bend. ( unit: mm)

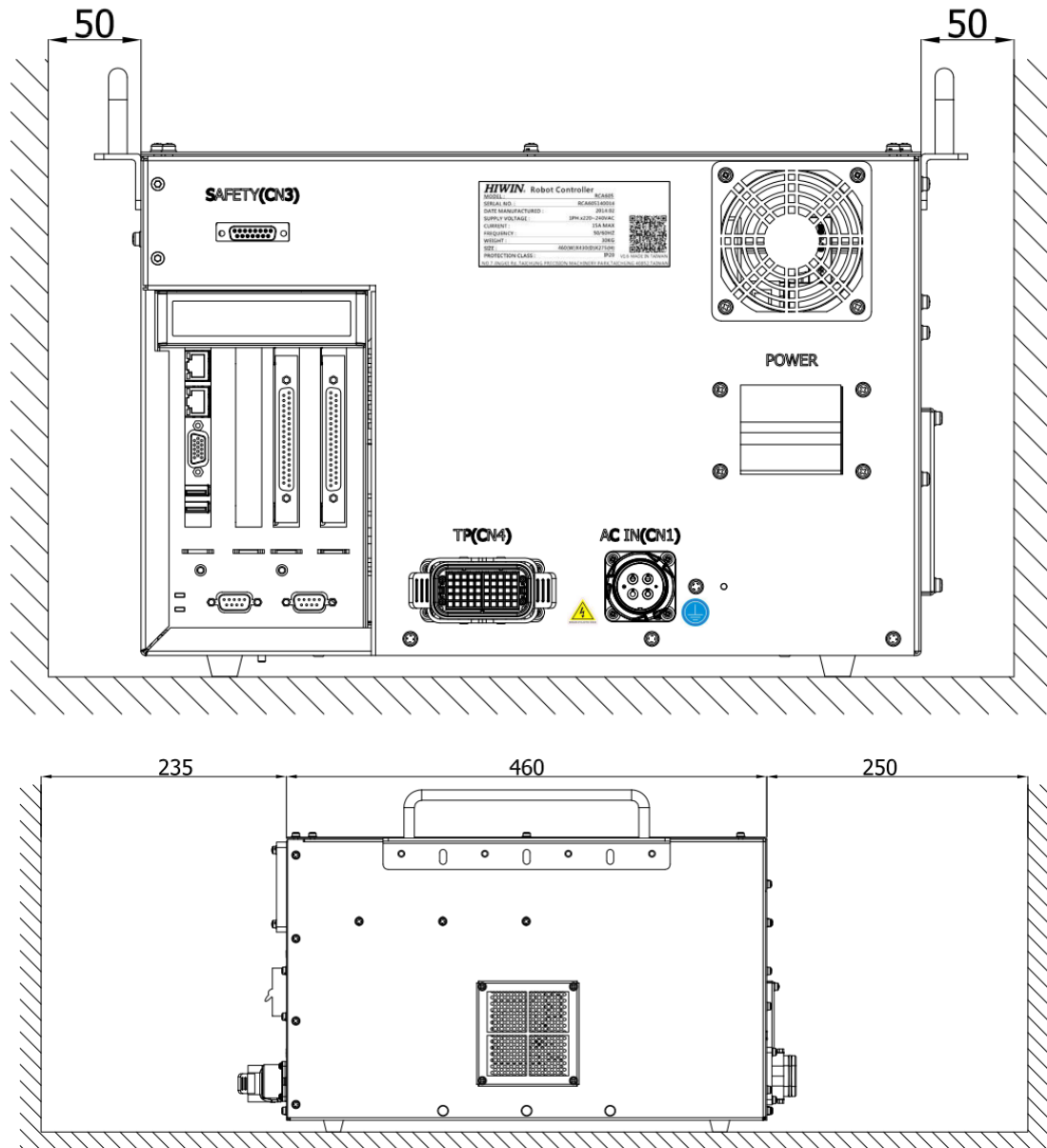

**CAUTION**

- ❖ Controller should keep upright while installing as the illustration shows. Flipping it 90 degrees on the side and turning it over 180 degrees are forbidden while installing the controller in the protection of the internal battery component.

The following shows the 610 series robot controller connector installation space.  
Please reserve some space for the connecting wires to avoid interference as they bend.

(unit: mm)

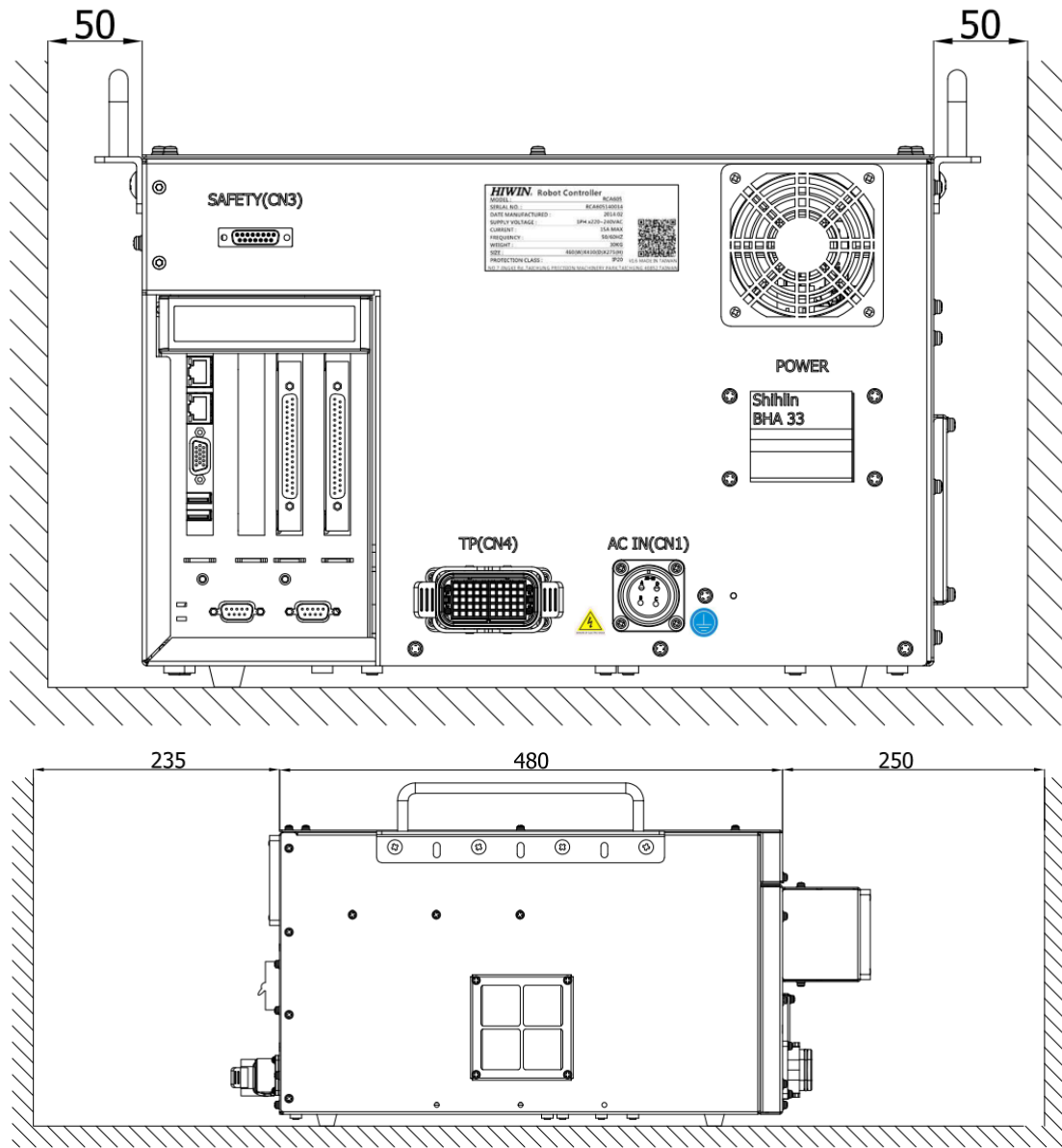

**CAUTION**

- ❖ Controller should keep upright while installing as the illustration shows. Flipping it 90 degrees on the side and turning it over 180 degrees are forbidden while installing the controller in the protection of the internal battery component.

## 2.2 Multifunctional Installation Frame

This controller is attached with two groups of multifunctional fixing frame while delivering (as shown below). The fixing frame can be installed on the controller with the handle, used for transportation. Or the controller can be fixed on other machines to use. The assembly method of the fixing frame and the handle is shown below. The specification of the screws is M6X1PX10L flat-head screw.

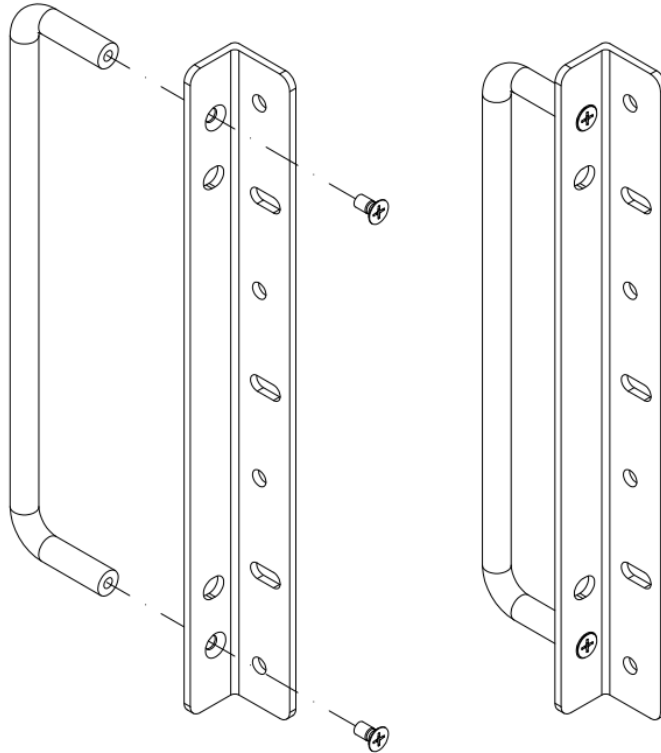

Multifunctional fixing frame can be installed on the controller. The assembly drawing is shown below. The specification of the screws is M6X1PX8L.

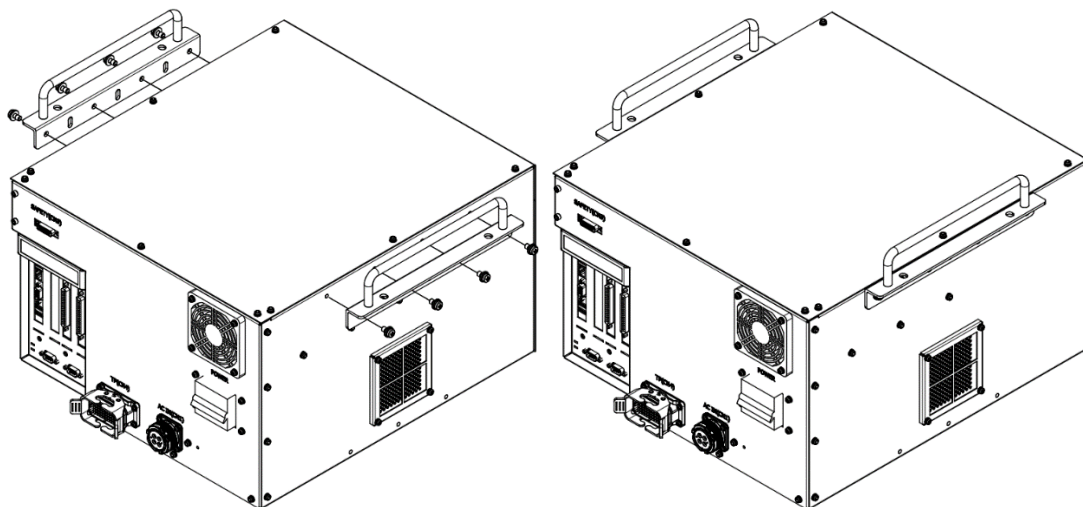



Multifunctional fixing frame can be installed under the controller. The assembly drawing is shown below. The specification of the screws is M6X1PX8L. This configuration is convenient for the operator to fix the controller on other machines.

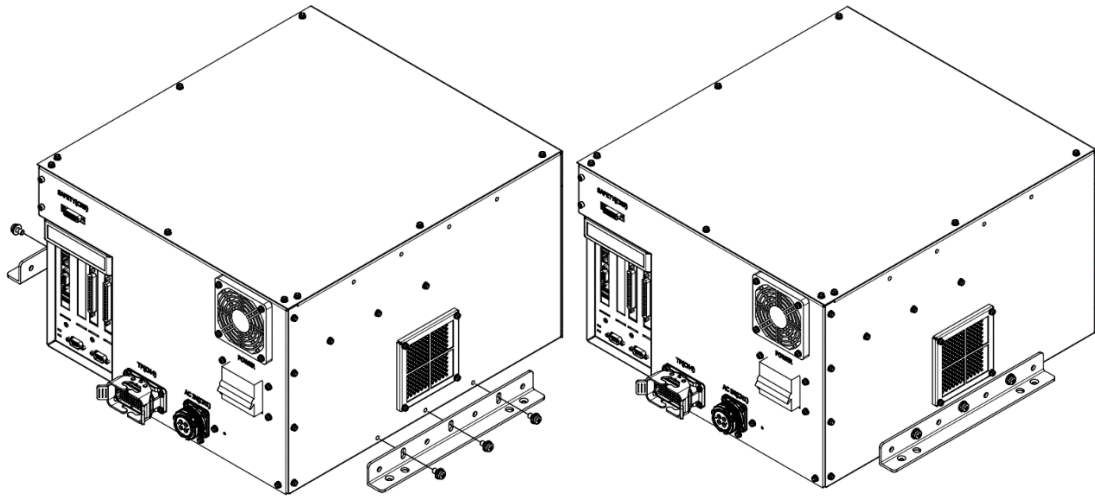

The corresponding dimensions of multifunctional fixing frame

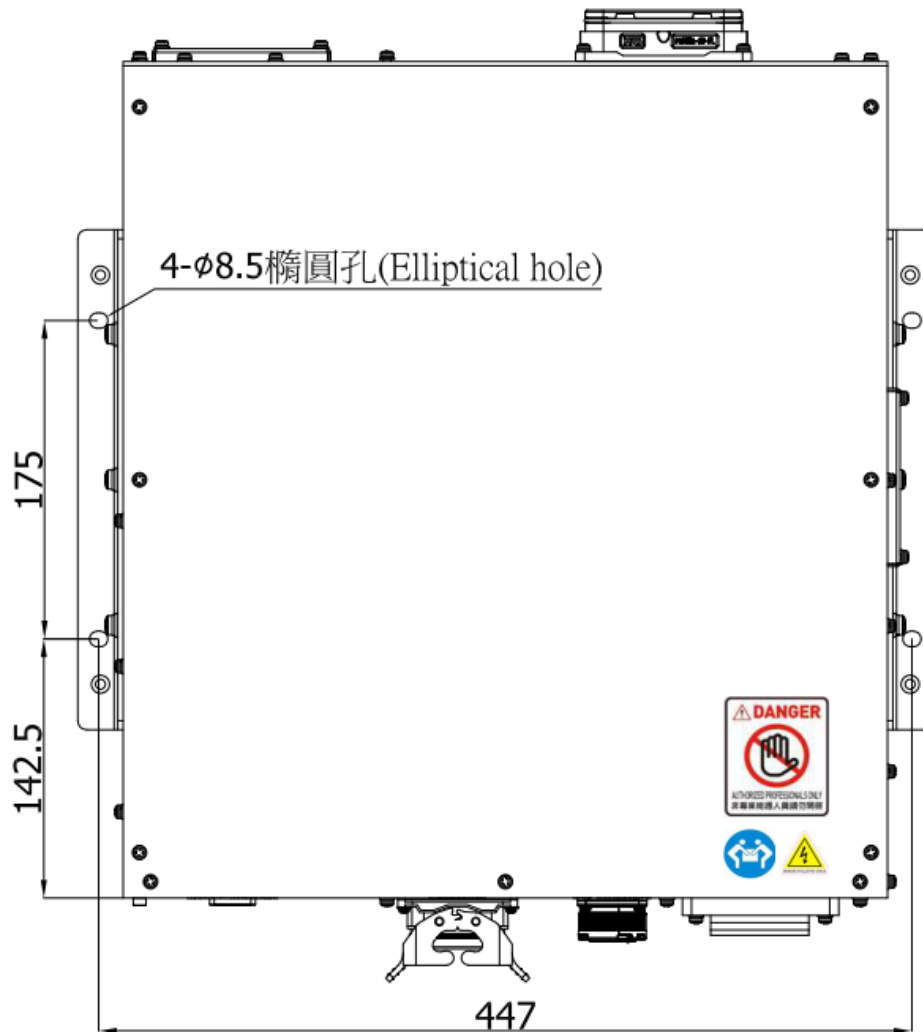

### 2.3 Overview of industrial robot

The picture below is an example of basic connection structure. RCA605, 610 controller needs to be supplied with single-phase AC200-240V, RCD403 controller needs to be supplied with three-phase AC200-240V, and the ground connection should be separated from main power breaker. Instead of connecting the ground by devices or system ground, the correct way is to connect to power ground directly, and high-quality wires whose diameters are 14AWG or more must be used. The power can be turned on and tested after connecting the main components mentioned below. Please make sure that the grounding of manipulator must connected to the power grounding directly.

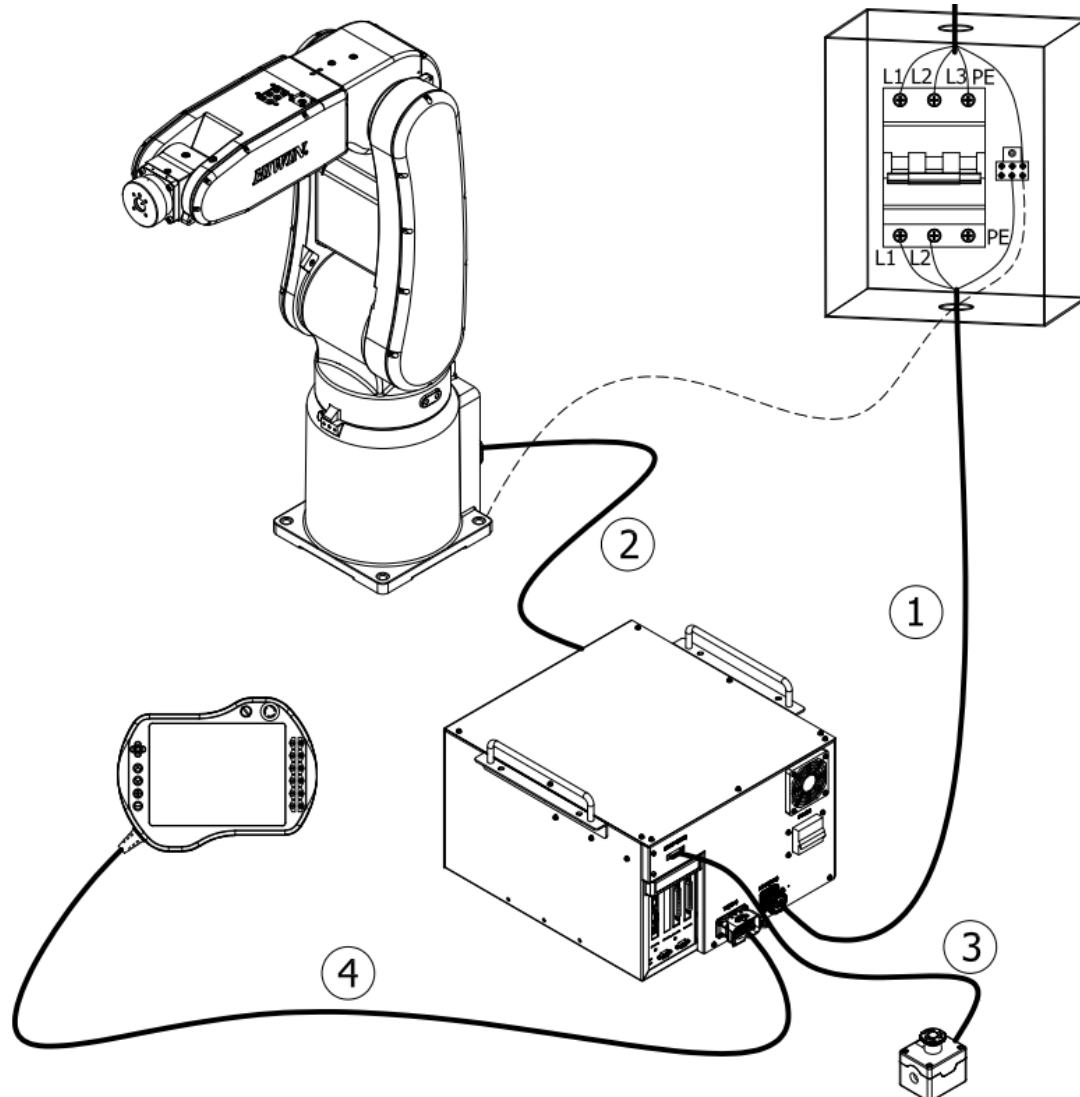

No.	RCA605-GB series basic connection structure
1	CN1 Main Power Cable
2	CN2 Power & Signal Cable
3	CN3 Emergency Stop Switch
4	CN4 Teach Pendant

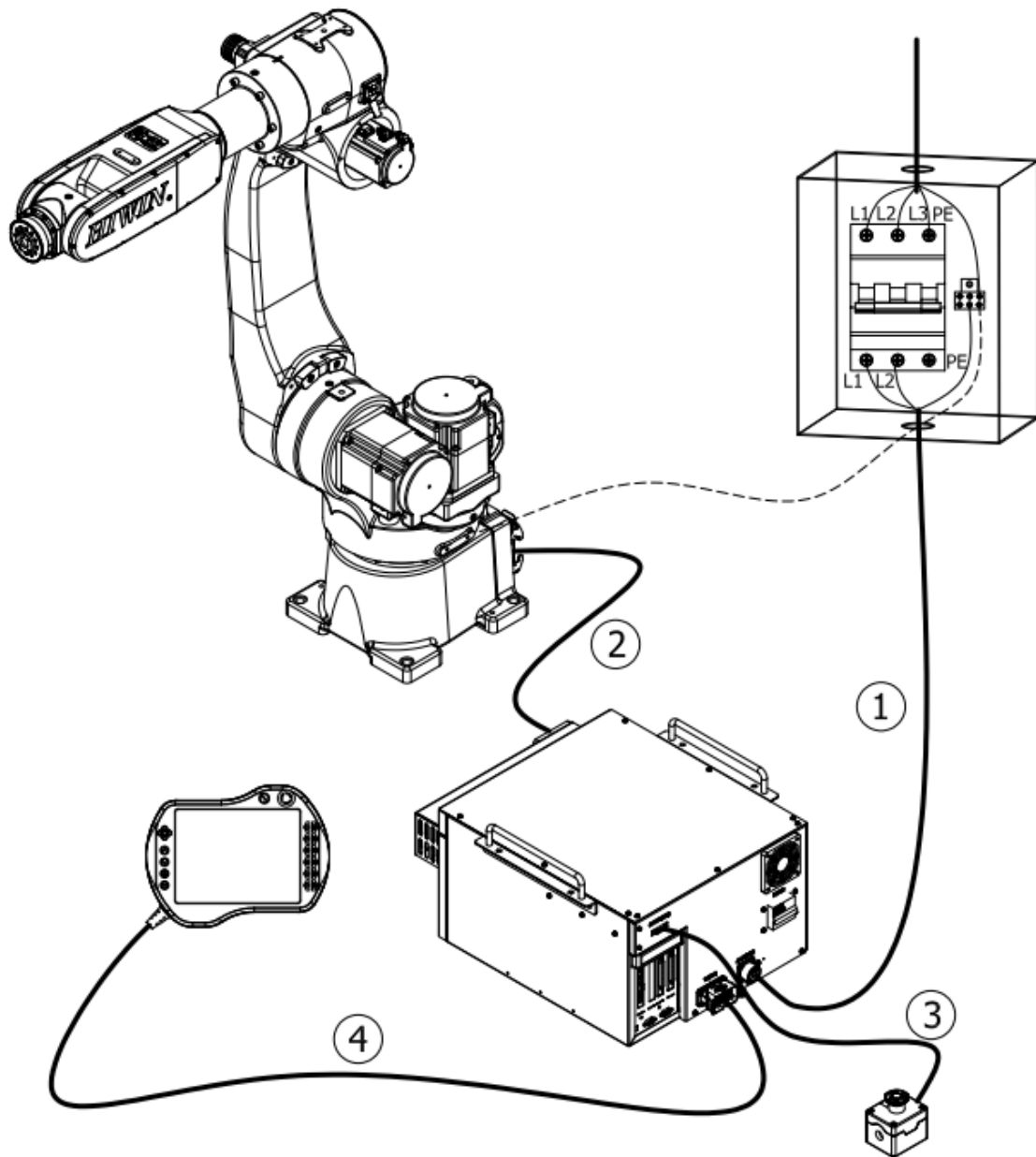

No.	RCA610-GB series basic connection structure
1	CN1 Main Power Cable
2	CN2 Power & Signal Cable
3	CN3 Emergency Stop Switch
4	CN4 Teach Pendant

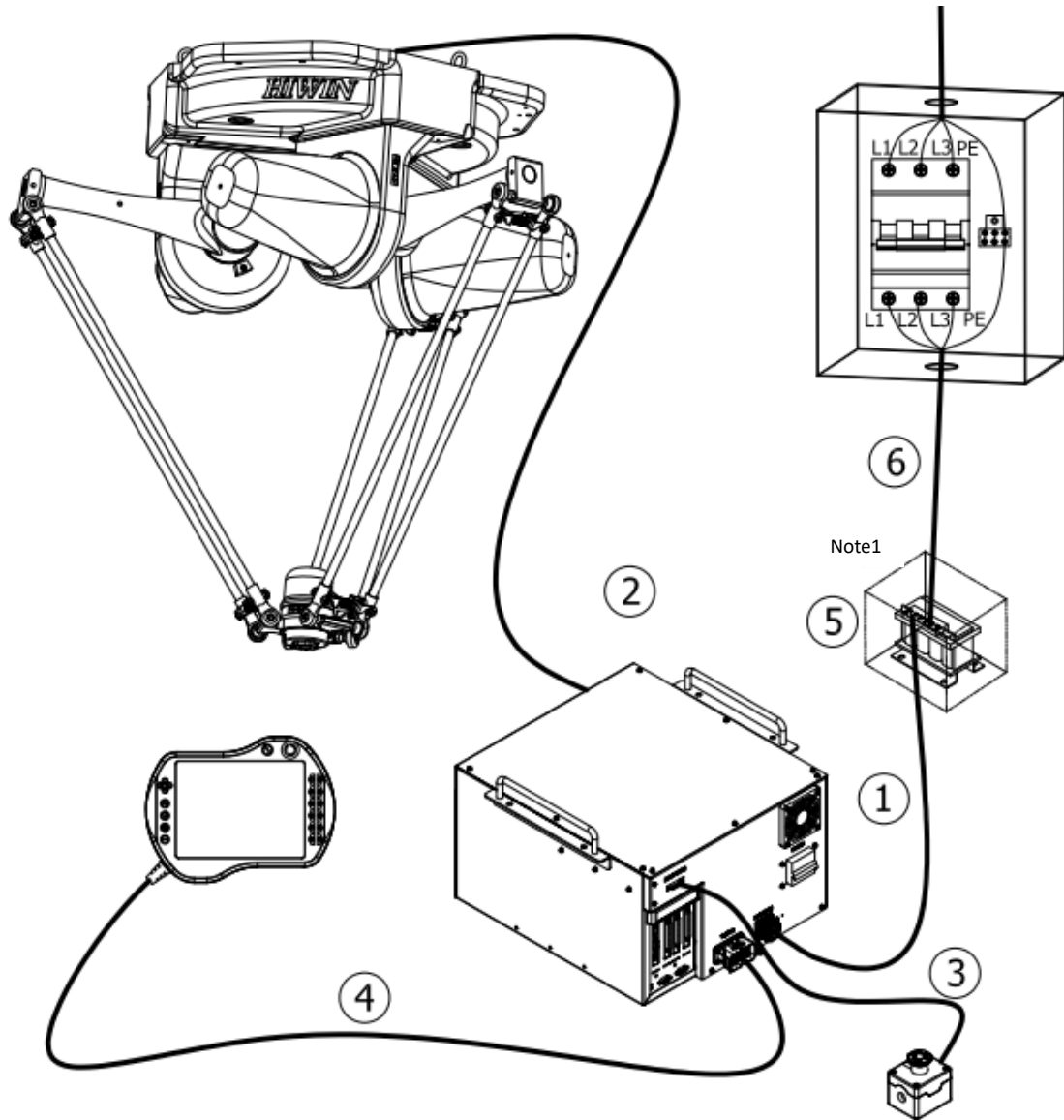

No.	RCD403-GB series basic connection structure
1	CN1 Main Power Cable
2	CN2 Power & Signal Cable
3	CN3 Emergency Stop Switch
4	CN4 Teach Pendant
5	Transformer <sub>(note1)</sub>
6	Transformer power cable <sub>(Note 1)</sub>

PS. Dimension: 415mmx320mmx370mm

\*Note 1: RCD403 series robot arm controller input voltage specification is three-phase 220V. If the power supply specifications of the client are different, the transformer must be connected in series.

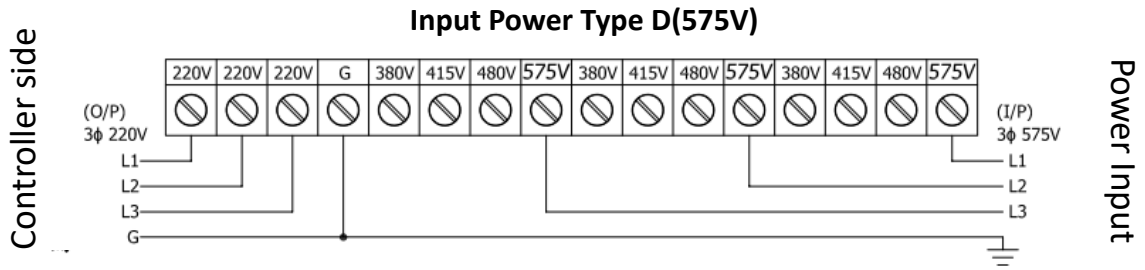
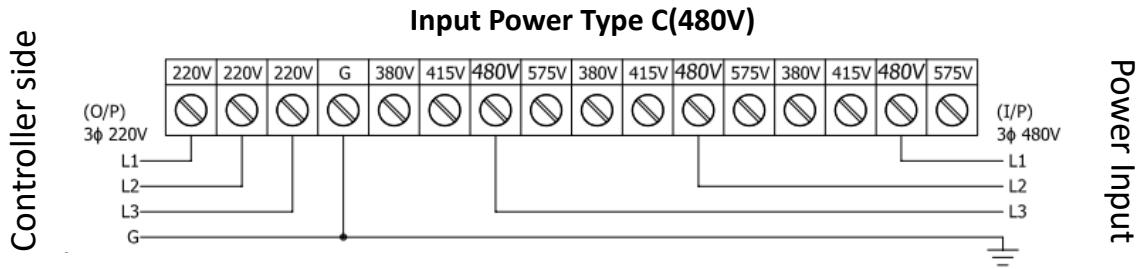
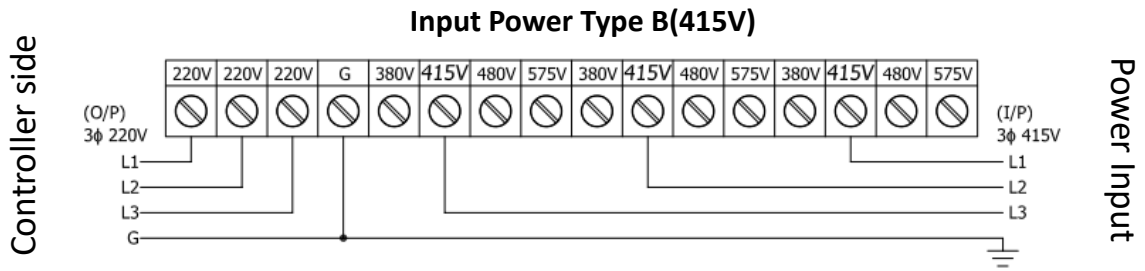
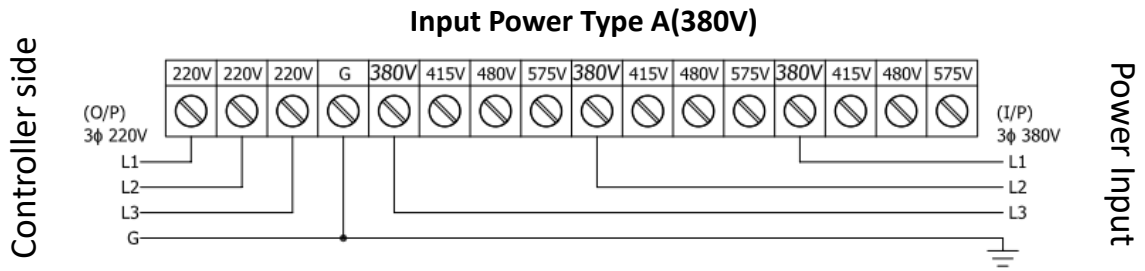

 <b>CAUTION</b>	<p>❖ Before running for a test, please make sure that the manipulator is securely installed to prevent from tipping during the motion.</p>
---	--

## 2.4 Controller Boot/Shutdown Program Description

Boot – Power on by flipping up the power switch.

Shutdown – HIWIN industrial robot (HRSS version 3.2.12 above, if having previous version, it is highly recommended to update the newest version) provided with 2 types of shutdown program. “Software shutdown” and “Digital input control shutdown” respectively, choose either one to execute:

### 1. Using software to shutdown -

Procedure for shutting down are as follows:

- (1) Stop the motion of the robot manipulator.
- (2) Press the emergency stop button.
- (3) Press the software shutdown button.

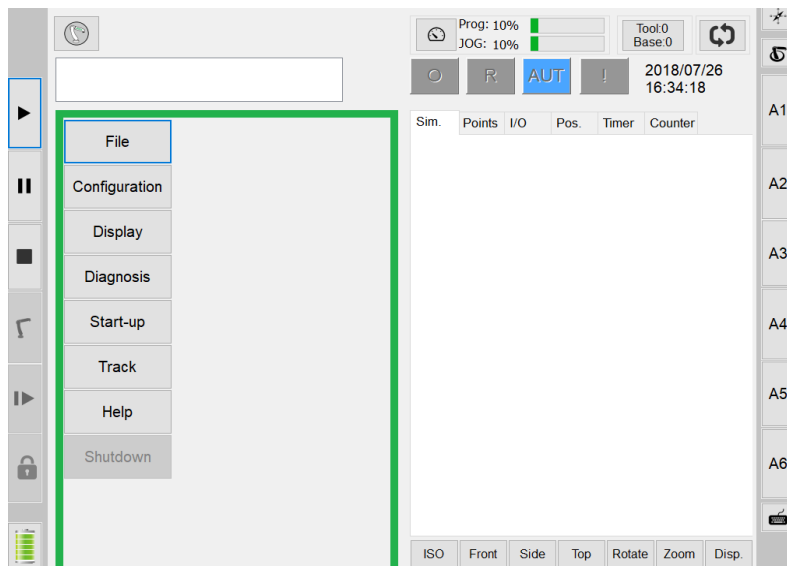

- (4) Wait at least 5 seconds before switching off the power. (Switch off the controller switch or cut off the main power directly)

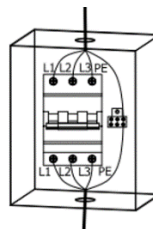
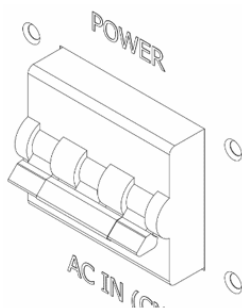

**CAUTION**

- ❖ Operator must not leave until the power switch is switched off.

2. Using digital input (DI) to control shutdown –  
Please set the option of DI/DO in the HRSS software program.  
The setting method is as follows:

**Step 1:**

Enter HRSS function page, click Start-up -> System Setting -> DIO Setting

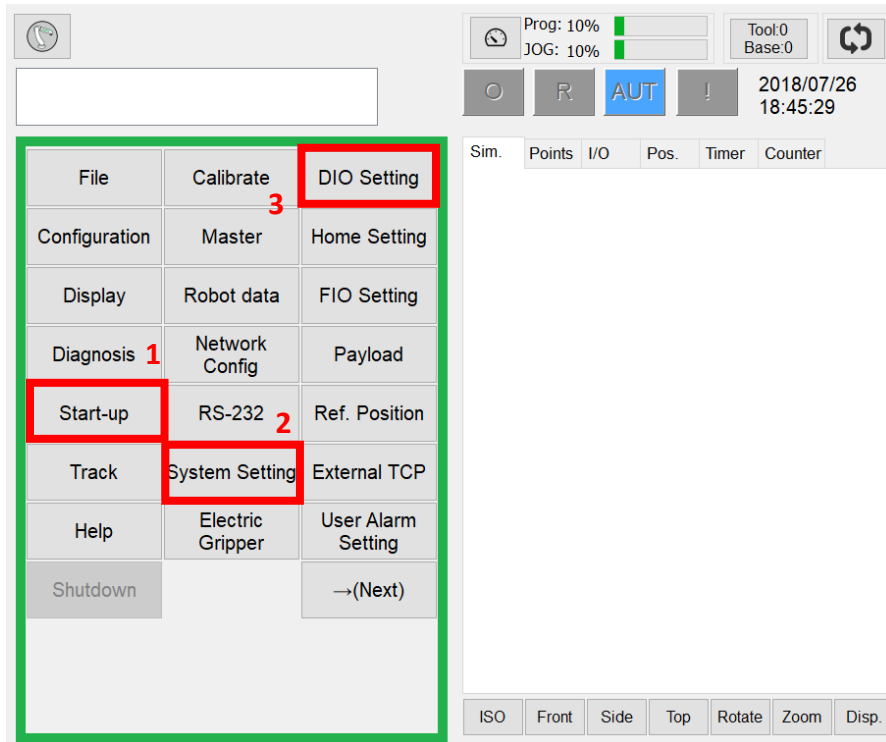

**Step 2:**

**DI setting**

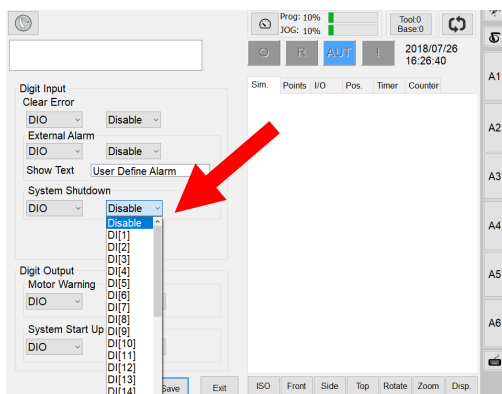

Please select the DI pin to be set by the customer.

**DO Setting**

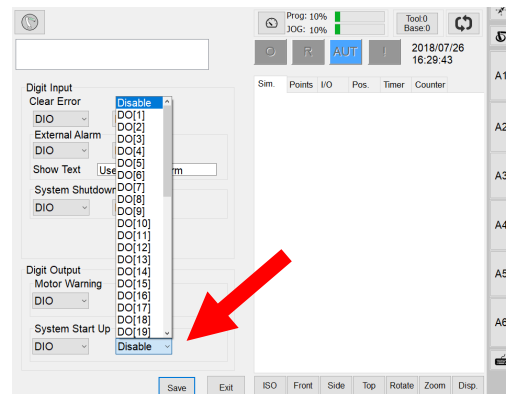

Please select the DO pin to be set by the customer.

Step 3:

Please press SAVE after setting.

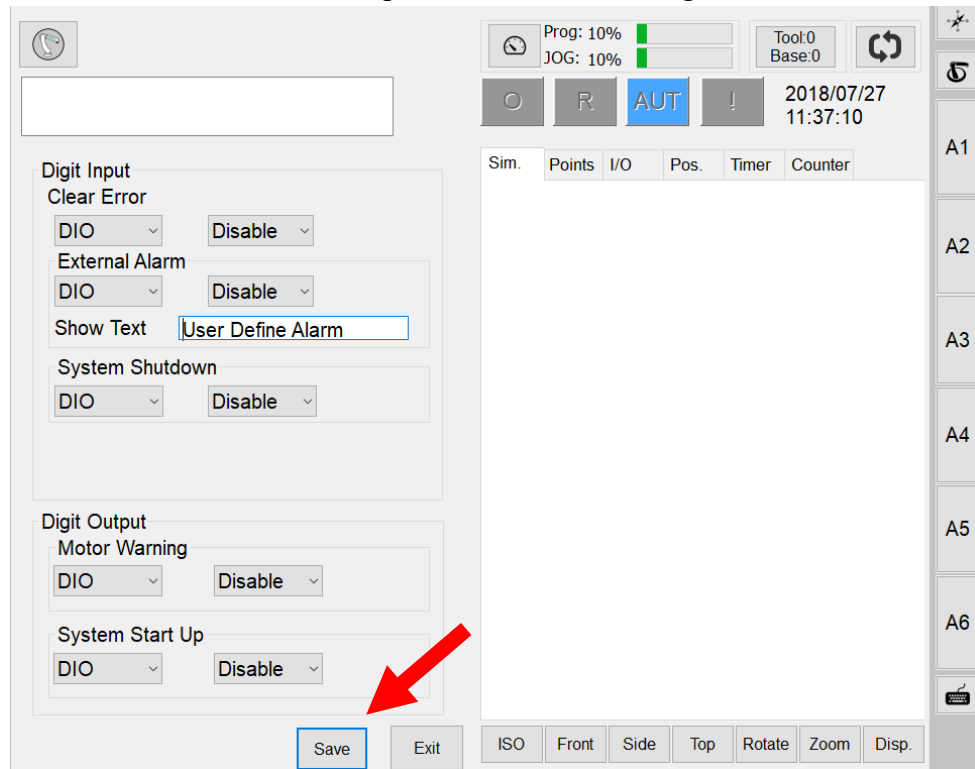

Procedure for shutting down are as follows:

- (1) Press the emergency stop button.
- (2) Two types of method: (select either one to execute)
  - a. After connecting digital input (DI) to trigger shutdown, wait at least 5 seconds before switching off the power. (Switch off the controller switch or cut off the main power directly)
  - b. After connecting digital input (DI) to trigger shutdown, the controller should receive the digital output (DO) feedback to switch off the power. (Automatically generated by the system without additional control) (Switch off the controller switch or cut off the main power directly)

 <b>CAUTION</b>	<p>❖ Operator must not leave until the power switch is switched off.</p>
---	--



**Digital Input Shutdown Timing:**

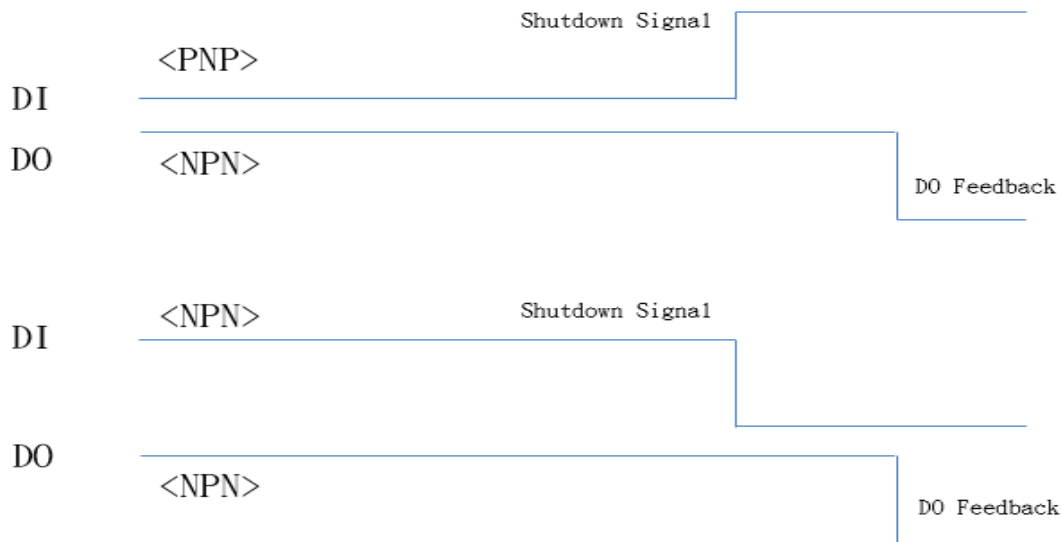

 <b>WARNING</b>	<ul style="list-style-type: none"> <li>❖ If the above procedure is not completed, please do not directly switch off the power switch on the controller or cut off the main power. Improper shutdown could cause damage to the controller.</li> <li>❖ Please wait for 30 seconds to reboot. Do not reboot immediately after switching off the power switch.</li> <li>❖ If stopping a robot in motion is required, please avoid using emergency button. To stop the program, press the stop button.</li> <li>❖ Please stop the motion of the manipulator before shutting down. Then perform the shutdown procedure to avoid unexpected danger when the power is cut off during the motion.</li> </ul>
---	---

**Power Off Safety Device: Padlock Accessories (For CE version only)**



 <b>CAUTION</b>	<ul style="list-style-type: none"> <li>❖ Please prepare your own padlock.</li> <li>❖ Please remove padlock before rebooting.</li> </ul>
---	---

Padlock select suggestion: The size of the padlock can be used as follows (mm)  
Weight < 45g

(A)	(B)	C	D	E	(F)	G
19~25	25~42	9~11.5	4~4.5	11~15	8~10	7.5~9

Note 1: (A)(B)(F) for reference size (not absolute necessary)

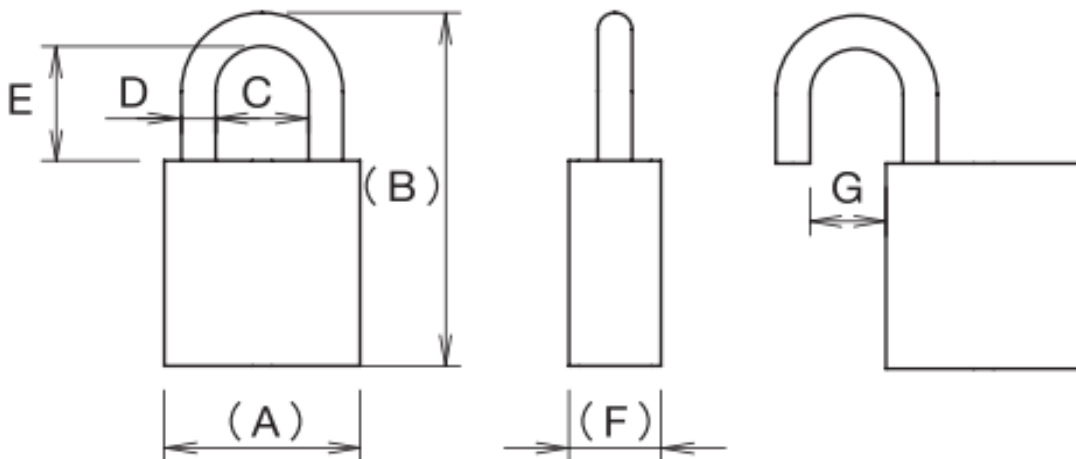

## 2.5 Power & Signal Cable Connection (CN2)

### Description:

Connect the power & signal cable (CN2) of the manipulator to the controller.

The standard specifications are as follows:

Applicable Model	Length	HIWIN Part No.
605 Series	3m	AH301L01
610 Series	5m	AH301W01
403 Series	5m	AH301A01



### Connection method:

<p>The motor connection port on the controller is CN2 connector which is designed fool-proofing function. If it cannot be plugged in, please rotate and connect it again.</p>	<p>MOTOR CONNECTOR (CN2) RCA605、RDA403 Series      MOTOR CONNECTOR (CN2) RCA610 Series</p>
<p>Plug the cable into CN2 connector, and secure the safety lock indeed.</p>	<p>MOTOR CONNECTOR (CN2)</p>



### WARNING

- ❖ Plug the connector in the direction parallel to the pins to avoid the internal pins being crooked and deformed.
- ❖ According to different operating condition, the temperature of the cable would rise slightly. Remove plastic cover before connection.
- ❖ Please avoid severe impact while installation.

## 2.6 Emergency Stop Switch Connection (CN3)

### Description:

Connector CN3 is a female DSUB-15 connector for emergency stop.

Emergency stop switch (optional equipment) is a button box with a 5m wire. It should be placed at the position, which is easy to reach. DSUB-15 soldering connector is included in the connector kit.

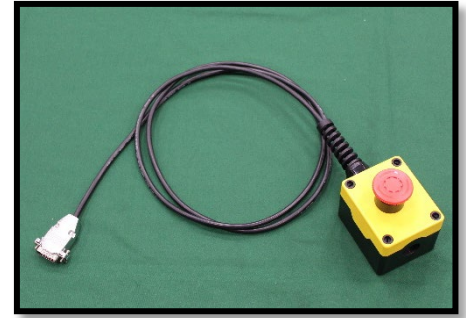

### Emergency stop switch wiring diagram

Controller emergency stop connector is a dual circuit contact, which should be connected with an external dual circuit emergency stop device additionally. This device should be a dry contact (uncharged) switch. Ensure the connector is connected correctly and the emergency stop device is accessible to the operator before the robot functions.

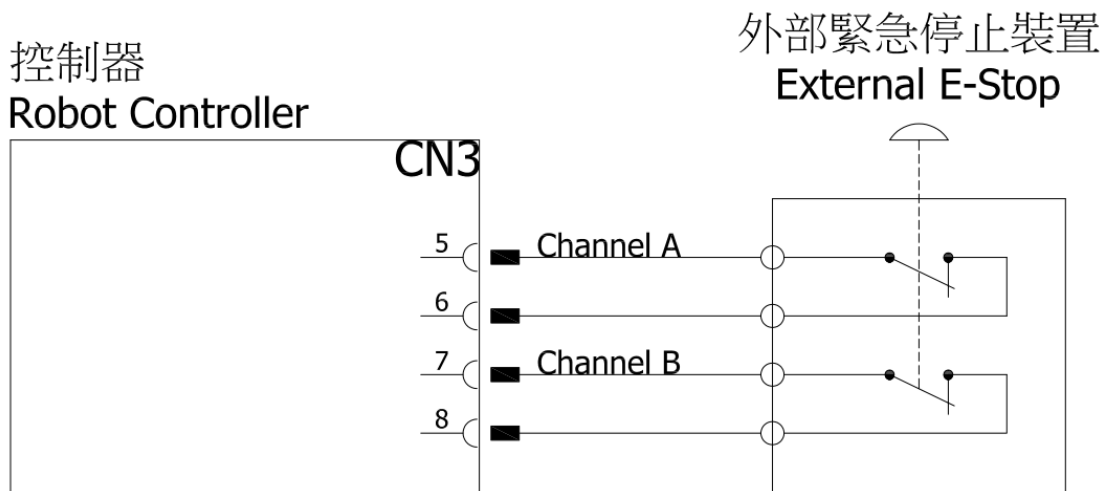

**DANGER**

- ❖ The emergency stop device must be connected with the controller and be placed at the position accessible to operator. Wrong method of using can cause a severe damage or loss of life and property.

**Connection Method:**

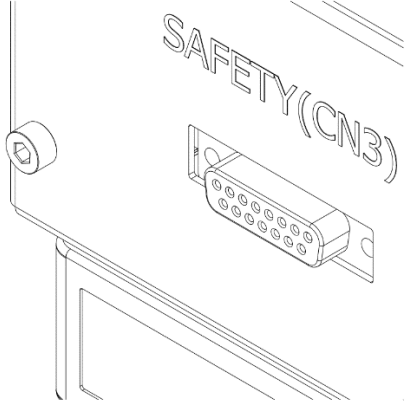
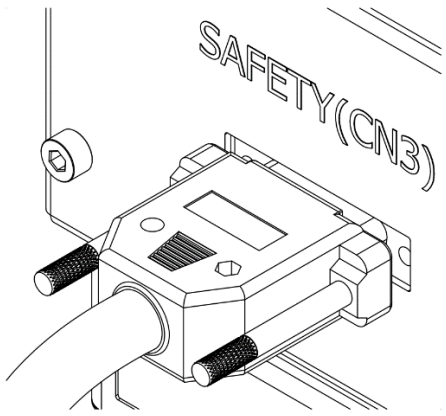
<p>The connector of emergency stop device on controller is CN3 which is designed fool-proofing function. If it cannot be plugged in, please rotate and connect it again.</p>	
<p>Plug the connector into CN3 and secure the screws indeed.</p>	

<p style="text-align: center;">   <b>CAUTION</b> </p>	<ul style="list-style-type: none"> <li>❖ Please ensure this emergency stop switch and the emergency stop on the teach pendant are all reset before the robot functions.</li> <li>❖ The external device connected to the emergency stop switch circuit should be dry contact (uncharged) switch. The charged circuit is forbidden.</li> </ul>
--	--

### 3. External Input / Output

**Description:**

External Input/ Output consists of two DSUB-37, including FI8/FO8 and DI24/DO24. An external I/O wiring set (optional equipment) contains connecting wire and terminal block. Connector kit contains DSUB-37 soldering connector. External I/O expansion module (optional equipment) can be expanded 16 more input and 16 more output.

There are two types of controller external I/O:

- (1) Function I/O (FI/O) → specific function I/O
- (2) Digital I/O (DI/O) → external I/O for customer's configuration

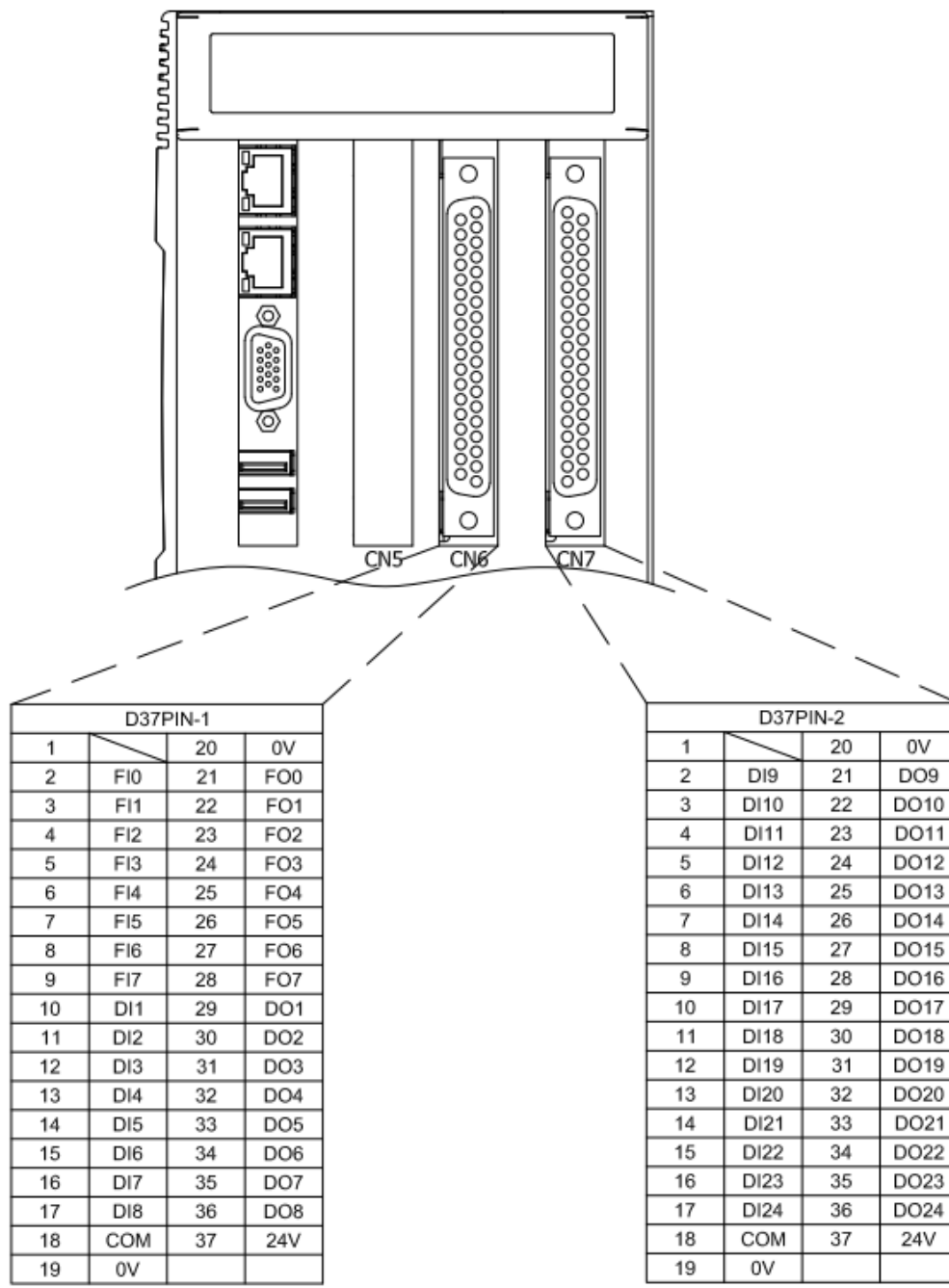

### 3.1 Function I/O

**Description:**

Standard equipment has function I/O of 8IN/8OUT, which are all in the D37PIN-1 connector.

**Function I/O List**

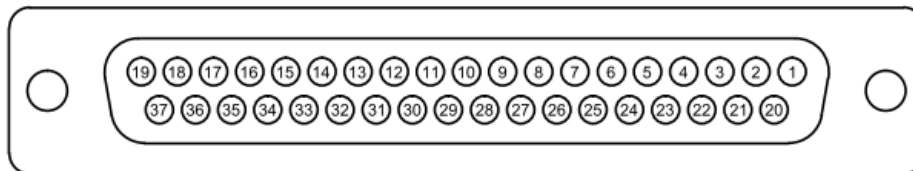

INPUT		
Pin	Parameter	Function
2	START	Execute program
3	HOLD	Pause program
4	STOP	Stop program
5	ENBL	Enable Function I/O
6	RSR1/PNS1	Robot service request 1 / program selection 1
7	RSR2/PNS2	Robot service request 2 / program selection 2
8	RSR3/PNS3	Robot service request 3 / program selection 3
9	RSR4/PNS4	Robot service request 4 / program selection 4
OUTPUT		
Pin	Parameter	Function
21	RUN	Program running
22	HELD	Program pausing
23	FAULT	Controller failure
24	READY	Controller ready
25	ACK1/SNO1	RSR 1 feedback signal / selection program No. 1
26	ACK2/SNO2	RSR 2 feedback signal / selection program No. 2
27	ACK3/SNO3	RSR 3 feedback signal / selection program No. 3
28	ACK4/SNO4	RSR 4 feedback signal / selection program No. 4

## 3.2 Digital I/O

### Description:

Standard equipment has 24IN/24OUT digital I/O, distributed in D37PIN-1 and D37PIN-2 connectors.

### Digital I/O List

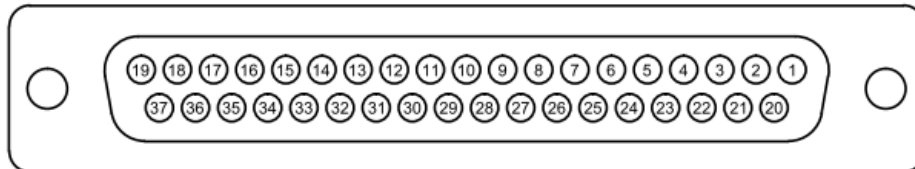

D37PIN-1			
Pin	Parameter	Pin	Parameter
10	DI[1]	29	DO[1]
11	DI[2]	30	DO[2]
12	DI[3]	31	DO[3]
13	DI[4]	32	DO[4]
14	DI[5]	33	DO[5]
15	DI[6]	34	DO [6]
16	DI[7]	35	DO [7]
17	DI[8]	36	DO [8]

D37PIN-2			
Pin	Parameter	Pin	Parameter
2	DI[9]	21	DO[9]
3	DI[10]	22	DO[10]
4	DI[11]	23	DO[11]
5	DI[12]	24	DO[12]
6	DI[13]	25	DO[13]
7	DI[14]	26	DO[14]
8	DI[15]	27	DO[15]
9	DI[16]	28	DO[16]
10	DI[17]	29	DO[17]
11	DI[18]	30	DO[18]
12	DI[19]	31	DO[19]
13	DI[20]	32	DO[20]
14	DI[21]	33	DO[21]
15	DI[22]	34	DO[22]
16	DI[23]	35	DO[23]
17	DI[24]	36	DO[24]



### 3.3 Example of Connection

1. External OUTPUT are all NPN (current sinking) output and OUTPUT signal is 0V. Pin20 (0V) and pin37 (24V) are supply voltage for OUTPUT which is supplied by external power source and the power connection cannot be reversed.
2. External INPUT can be NPN (current sinking) or PNP (current sourcing) input, adjusted with pin18 (COM). Pin19 (0V) is supply voltage for INPUT which is supplied by external power source and the power connection cannot be reversed.  
COM→24V: NPN INPUT  
COM→0V: PNP INPUT
3. Pin20 (0V) and pin37 (24V) of OUTPUT in the same DSUB-37 connector are the supply voltage, which should be connected to the same power supply.
4. Pin 18 (COM) and pin19 (0V) of INPUT in the same DSUB37 connector should be connected to the same power supply. The COM voltage level, which is the same, cannot be separated.
5. OUTPUT and INPUT in the same DSUB-37 connector can be connected to different power supplies to provide reference voltage level.
6. D37PIN-1 and D37PIN-2 can be connected to different power supplies to provide reference voltage level.

 <b>CAUTION</b>	<ul style="list-style-type: none"> <li>❖ The maximum current at the single output supplied by external output is 100mA.</li> <li>❖ The OUTPUT supplied by controller is all NPN output, which cannot be modified. The INPUT can be modified into NPN or PNP type by adjusting COM voltage.</li> </ul>
---	---

D37PIN-1

INPUT: NPN    OUTPUT: NPN

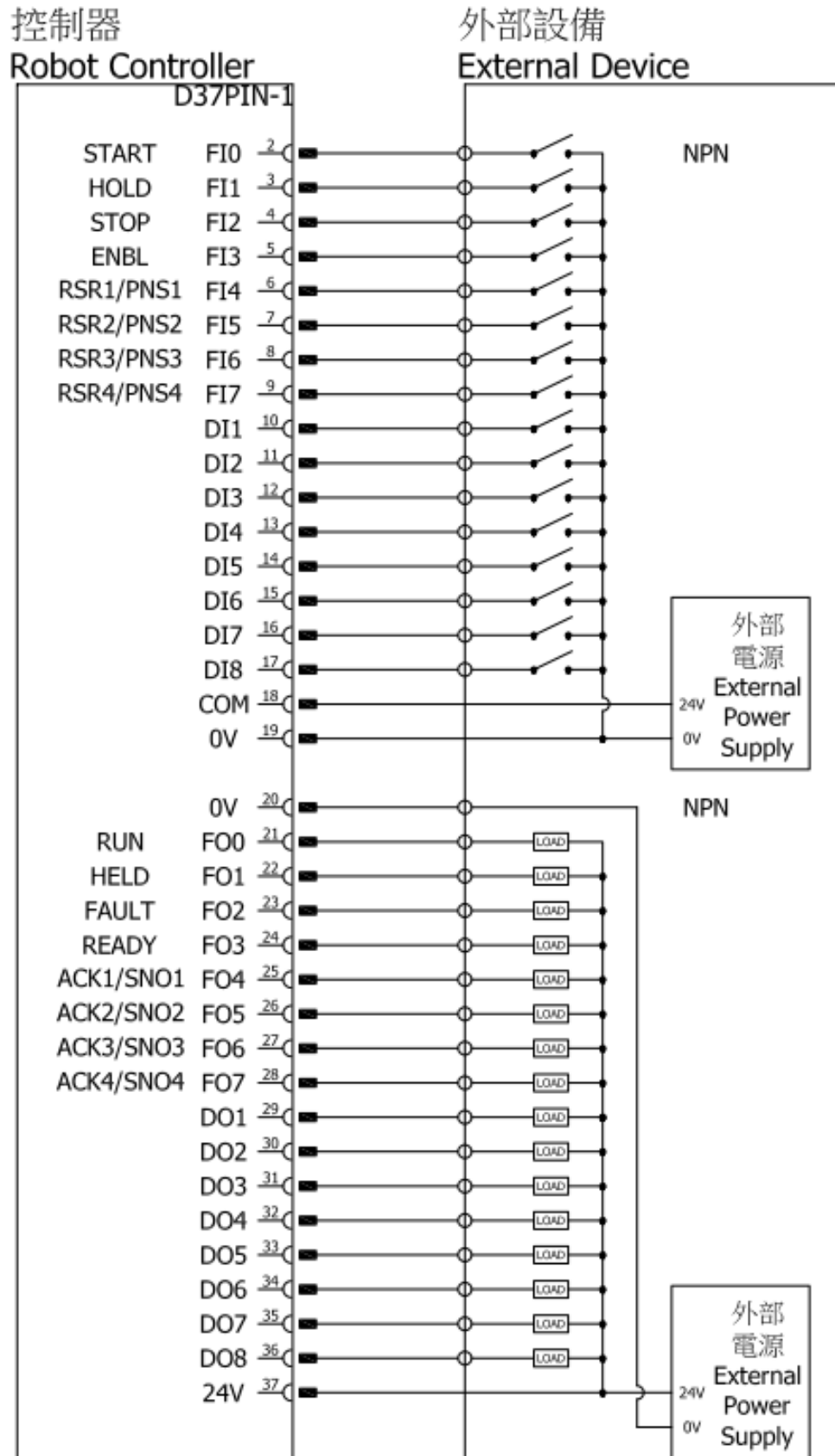

D37PIN-1

INPUT: PNP OUTPUT: NPN

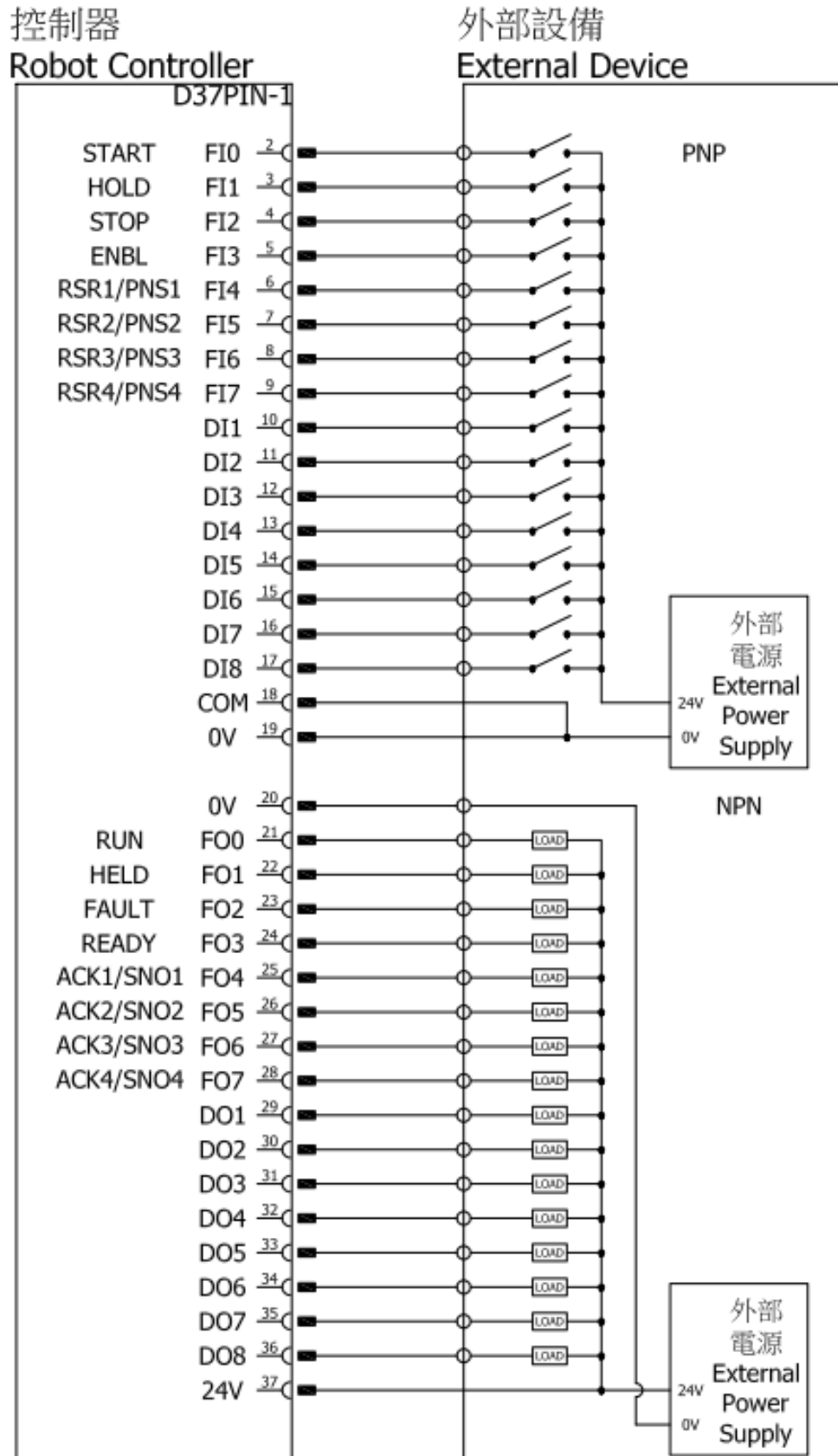

D37PIN-2

INPUT: NPN OUTPUT: NPN

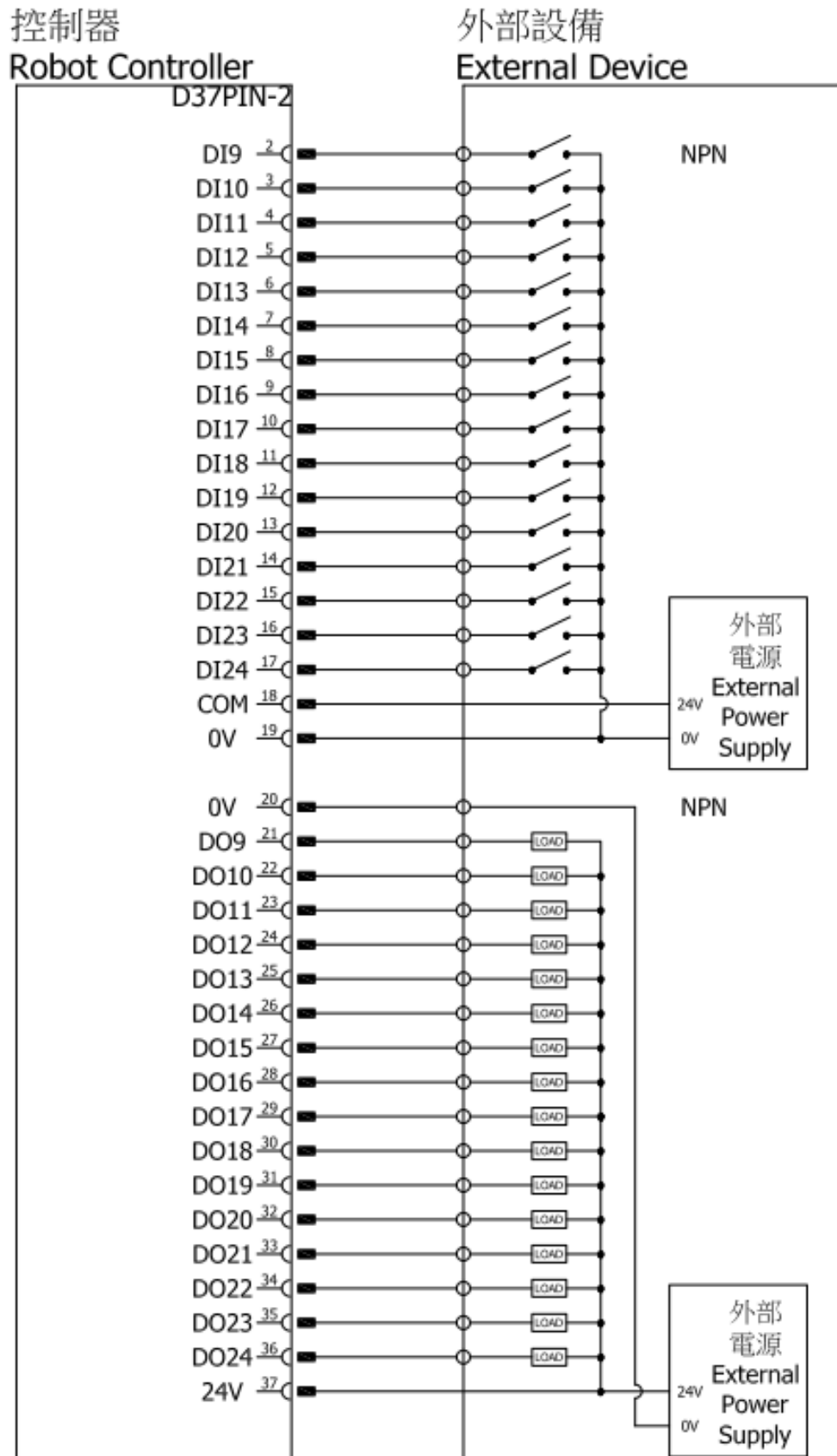

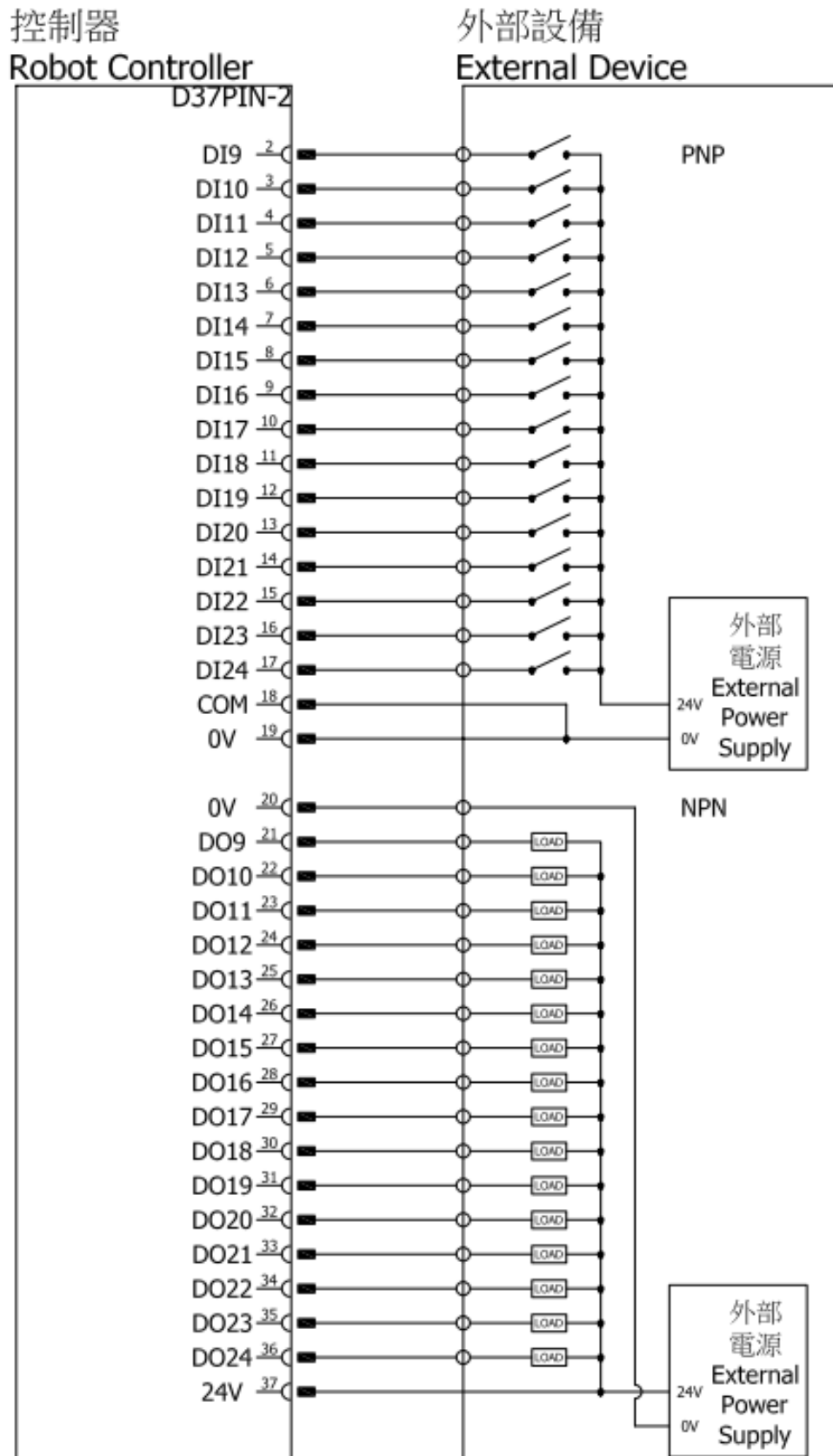

D37PIN-2

INPUT: PNP OUTPUT: NPN

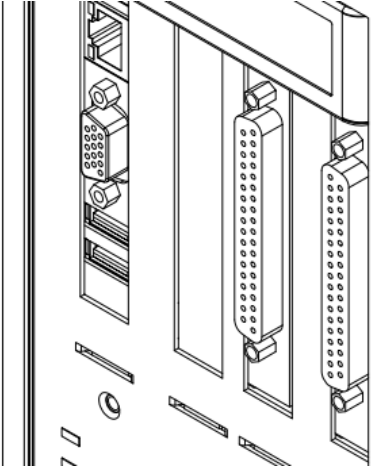
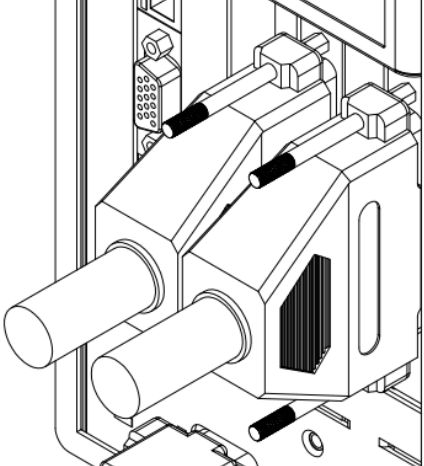

**Connection method:**

<p>There are two I/O connectors (DSUB-37) on the controller which is designed fool-proofing function. If it cannot be plugged in, please rotate and connect it again.</p>	
<p>Plug the connector in and secure the screw indeed.</p>	

 <p><b>DANGER</b></p>	<ul style="list-style-type: none"> <li>❖ No signal or power supply should be close to or in contact with any metal case. Wrong method of using can cause a severe damage or loss of life and property.</li> </ul>
--	---

 <p><b>WARNING</b></p>	<ul style="list-style-type: none"> <li>❖ To prevent the internal component from damage, any wiring operation must be done only when the controller is disconnected.</li> </ul>
---	--

 <p><b>CAUTION</b></p>	<ul style="list-style-type: none"> <li>❖ Please make sure the screws on the connector are secured.</li> </ul>
---	---

### 3.4 RCA605、610 External I/O Expansion Module

External I/O expansion module are all digital I/O and the pin assignment is shown below:

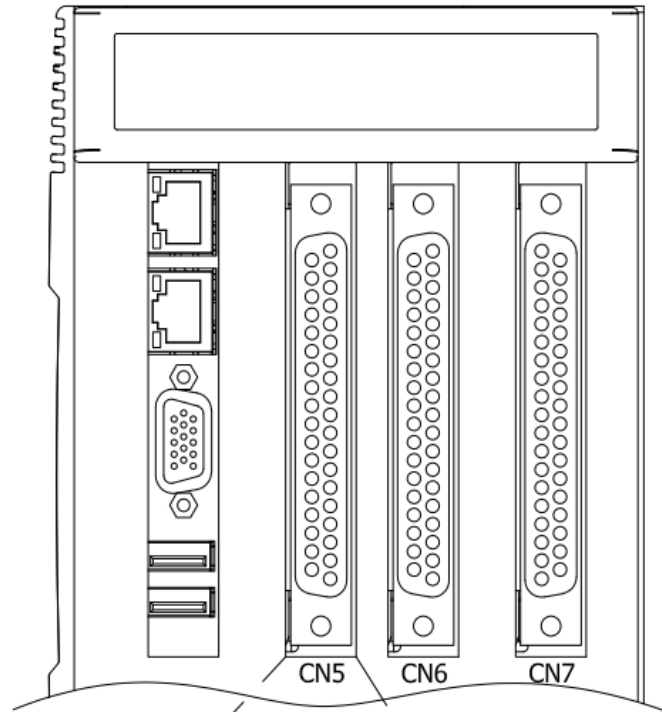

D37PIN-3			
1		20	0V
2	DI25	21	DO25
3	DI26	22	DO26
4	DI27	23	DO27
5	DI28	24	DO28
6	DI29	25	DO29
7	DI30	26	DO30
8	DI31	27	DO31
9	DI32	28	DO32
10	DI33	29	DO33
11	DI34	30	DO34
12	DI35	31	DO35
13	DI36	32	DO36
14	DI37	33	DO37
15	DI38	34	DO38
16	DI39	35	DO39
17	DI40	36	DO40
18	COM	37	24V
19	0V		

**Description:**

External I/O expansion module has 16IN/16OUT digital I/O, distributed in D37PIN-3 connector.

**External Expansion I/O List**

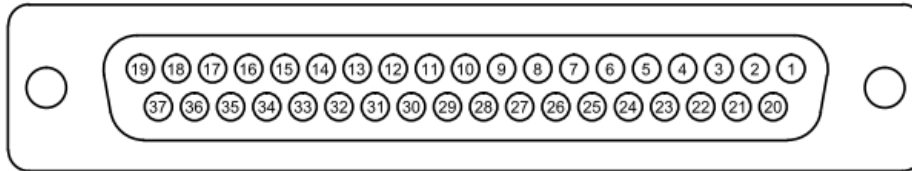

D37PIN-3			
Pin	Parameter	Pin	Parameter
2	DI[25]	21	DO[25]
3	DI[26]	22	DO[26]
4	DI[27]	23	DO[27]
5	DI[28]	24	DO[28]
6	DI[29]	25	DO[29]
7	DI[30]	26	DO[30]
8	DI[31]	27	DO[31]
9	DI[32]	28	DO[32]
10	DI[33]	29	DO[33]
11	DI[34]	30	DO[34]
12	DI[35]	31	DO[35]
13	DI[36]	32	DO[36]
14	DI[37]	33	DO[37]
15	DI[38]	34	DO[38]
16	DI[39]	35	DO[39]
17	DI[40]	36	DO[40]



D37PIN-3

INPUT: NPN    OUTPUT: NPN

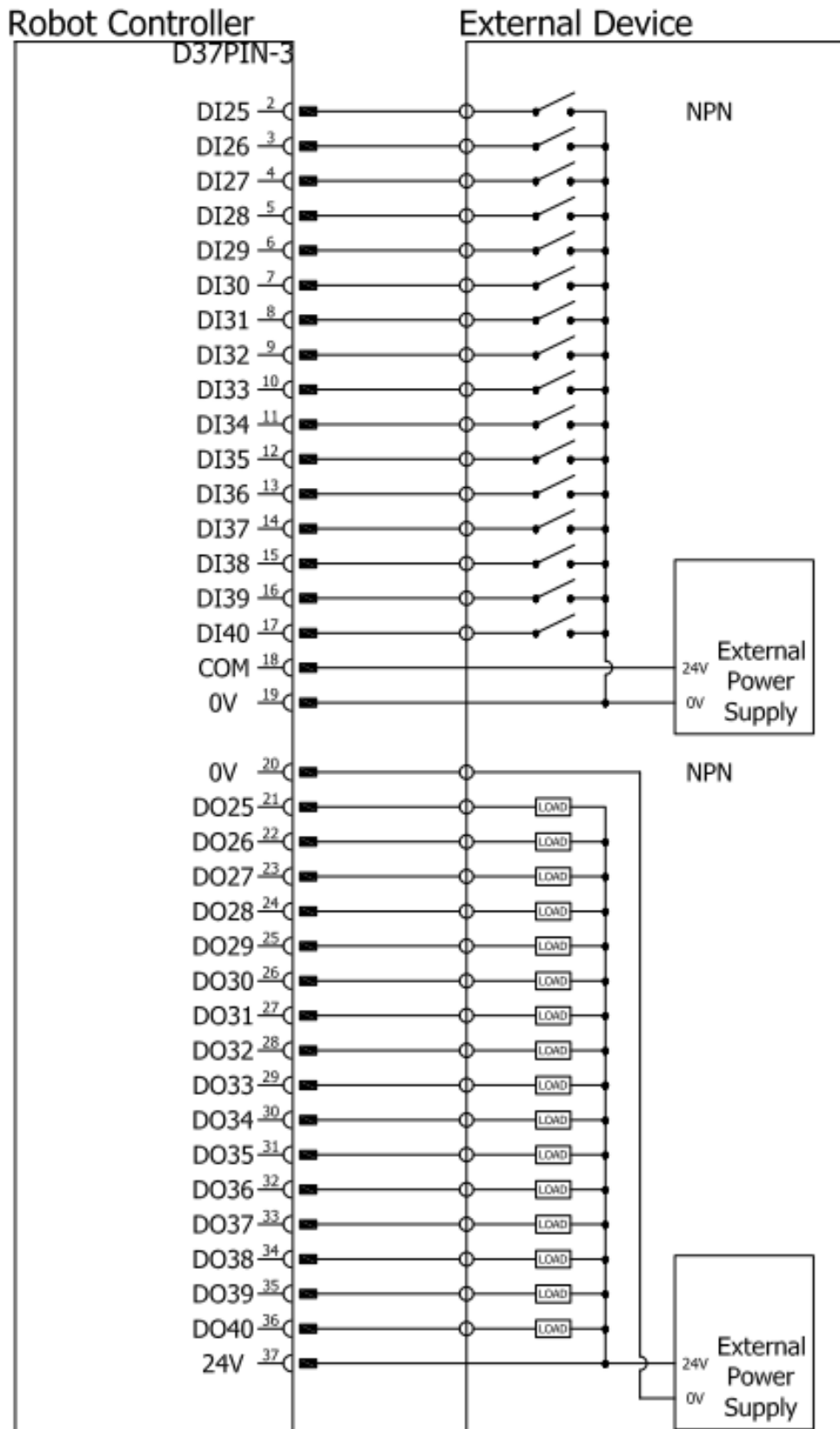

D37PIN-3

INPUT: PNP OUTPUT: NPN

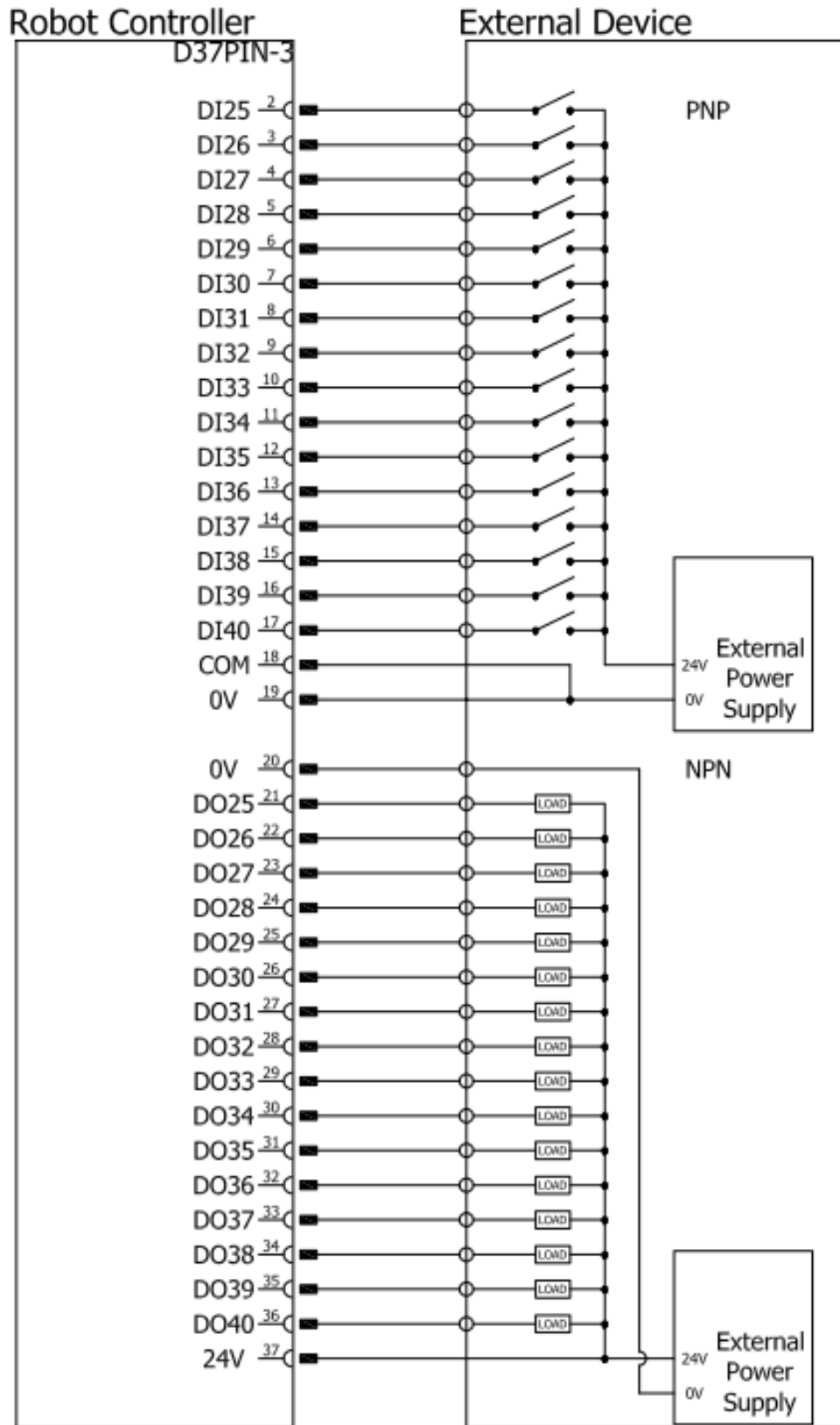

### 3.5 RCD403 Encoder Capture Module (CN5)

Description:

There are four channels in the encoder, CH1~CH4, the channel Latch signals are IDI1~IDI4. IDI COM can change the input to NPN or PNP according to operation.

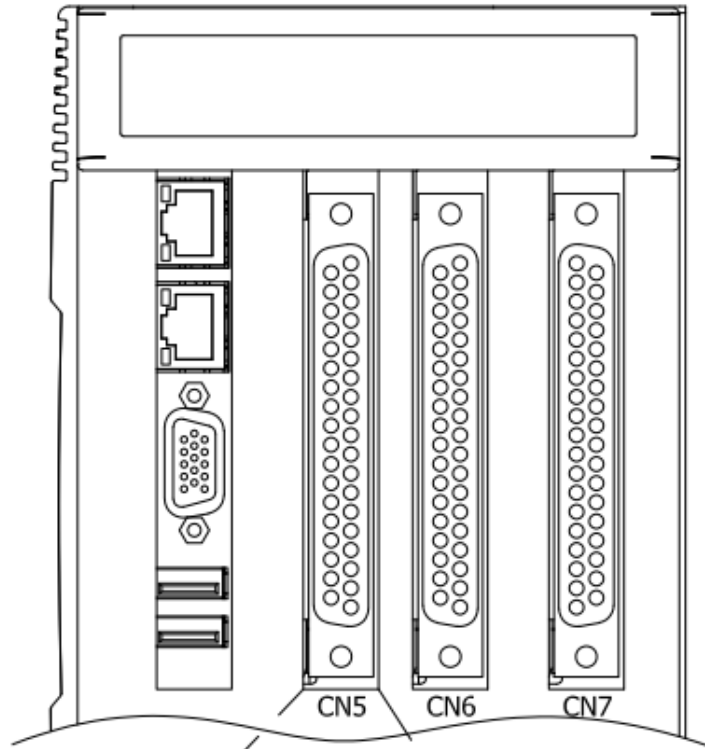

D37PIN-3			
1	EGND	20	CH1 A-
2	CH1 A+	21	CH1 B-
3	CH1 B+	22	CH1 Z-
4	CH1 Z+	23	CH2 A-
5	CH2 A+	24	CH2 B-
6	CH2 B+	25	CH2 Z-
7	CH2 Z+	26	CH3 A-
8	CH3 A+	27	CH3 B-
9	CH3 B+	28	CH3 Z-
10	CH3 Z+	29	CH4 A-
11	CH4 A+	30	CH4 B-
12	CH4 B+	31	CH4 Z-
13	CH4 Z+	32	EGND
14	IDI COM	33	IDI 2
15	IDI 1	34	IDI 4
16	IDI 3	35	EGND
17	EGND		

**Encoder List**

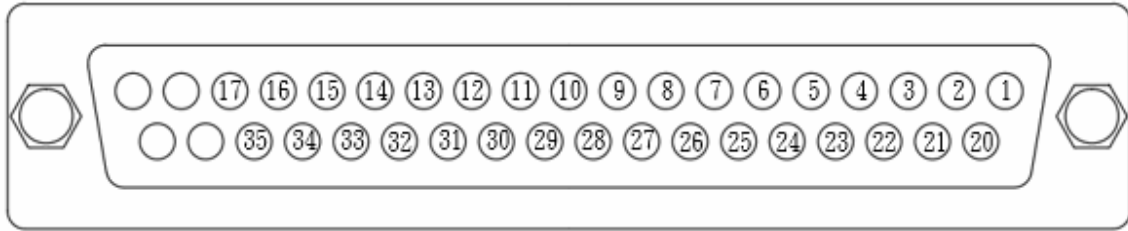

Pin	Parameter	Pin	Parameter
1	EGND	20	CH1A-
2	CH1A+	21	CH1B-
3	CH1B+	22	CH1Z-
4	CH1Z+	23	CH2A-
5	CH2A+	24	CH2B-
6	CH2B+	25	CH2Z-
7	CH2Z+	26	CH3A-
8	CH3A+	27	CH3B-
9	CH3B+	28	CH3Z-
10	CH3Z+	29	CH4A-
11	CH4A+	30	CH4B-
12	CH4B+	31	CH4Z-
13	CH4Z+	32	GND
14	IDICOM	33	IDI2
15	IDI1	34	IDI4
16	IDI3	35	EGND
17	EGND		



**CAUTION**

❖ The maximum current at the single output supplied is 50mA.

**Actual Wiring Example**

Take OMRON E6B2-CWZ1X as an example, the encoder required extra supply of 5V, CH1 as an input example.

Color	Terminal
Brown	Power supply(+V <sub>cc</sub> )
Blue	0V(common)
Black	Output phase A
White	Output phase B
Orange	Output phase Z
Black/red stripes	Output phase $\bar{A}$
White/red stripes	Output phase $\bar{B}$
Orange/red stripes	Output phase $\bar{Z}$

控制器

Robot Controller

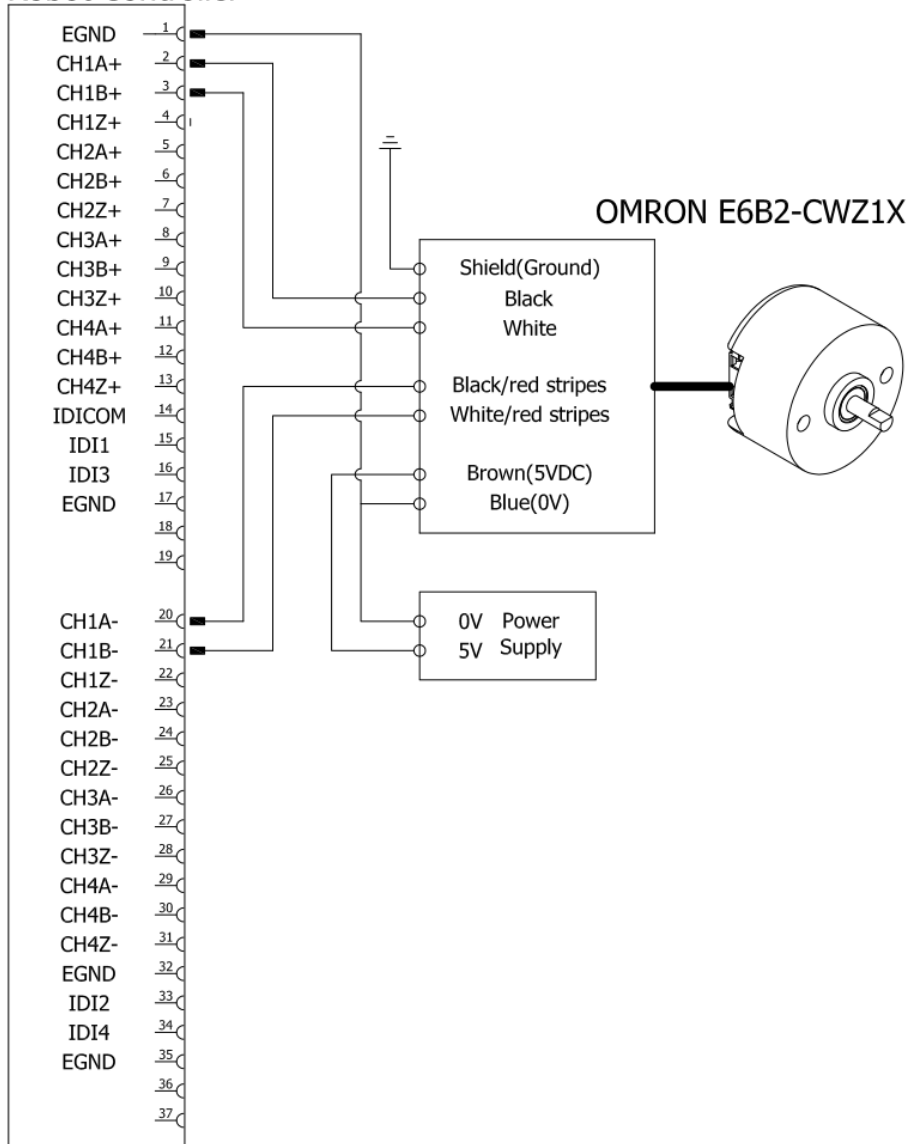

### 3.6 RS-232 Port

**Description:**

The following figure shows the pin assignment of RS-232 controller.

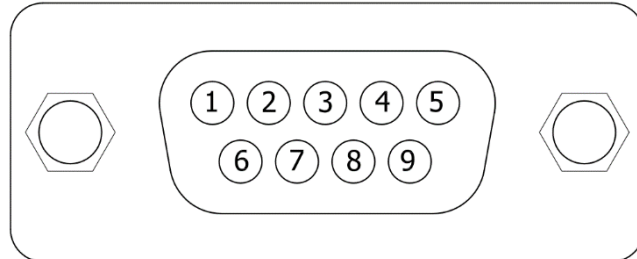

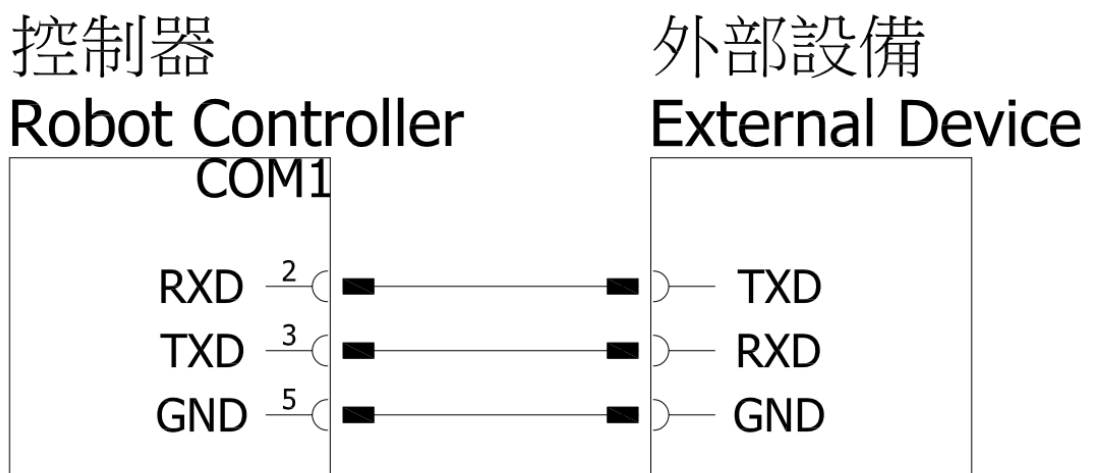

Pin	Description
2	RXD-Receiver
3	TXD-Transmit
5	GND -Ground

The following figure shows the connection method with external device.

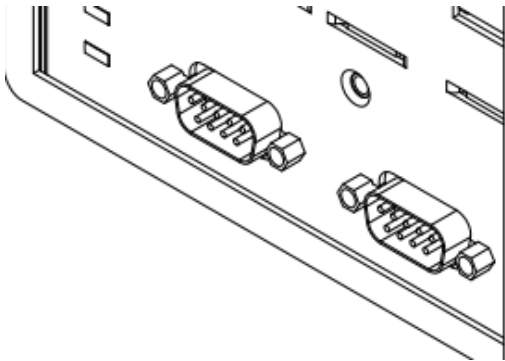
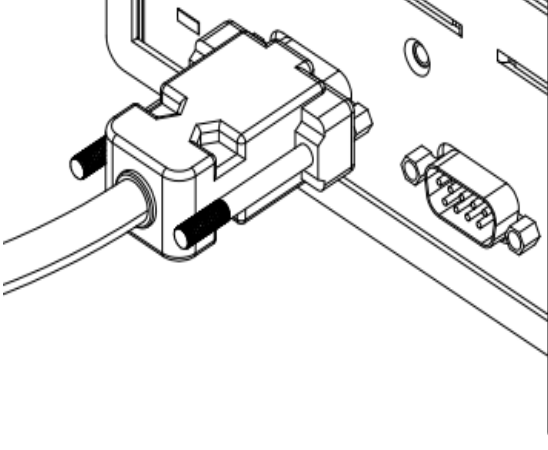

**Connection method:**

<p>The I/O connector of controller is COM1, which is designed fool-proofing function. If it cannot be plugged in, please rotate and connect it again.</p>	
<p>Plug the connector in and secure the screw indeed.</p>	

<p style="text-align: center;">   <b>DANGER</b> </p>	<ul style="list-style-type: none"> <li>❖ No signal or power supply should be close to or in contact with any metal case. Wrong method of using can cause a severe damage or loss of life and property.</li> </ul>
---	---

<p style="text-align: center;">   <b>WARNING</b> </p>	<ul style="list-style-type: none"> <li>❖ To prevent the internal component from damage, any wiring operation must be done only when the controller is disconnected.</li> </ul>
--	--

<p style="text-align: center;">   <b>CAUTION</b> </p>	<ul style="list-style-type: none"> <li>❖ Please make sure the screws on the connector are secured.</li> </ul>
--	---

## 4. Teach Pendant

### Description:

The Teach Pendant provides the program edit, program management and motion position teaching etc. In addition, for user's safety, the Teach Pendant is equipped with the Emergency Stop Switch and the Enable Switch

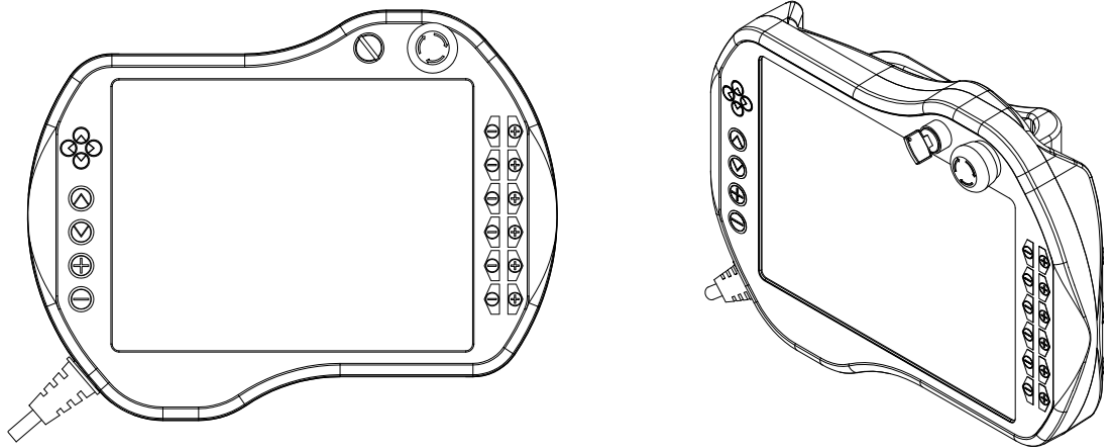

### Teach Pendant Specification:

Item	HIWIN Robot Teach Pendant
Model No.	TP02
Dimensions	318x245x107 mm <sup>3</sup>
Weight	2.5kg
Protection Rating	IP20
Display	10.2" touch screen
Resolution	1024x768 pixels
Mode	Manual, Auto and Lock
Physical Button	20keys + Enable Switch + Emergency Stop Switch + Key Switch
Cable Length	5m



### WARNING

- ❖ It is forbidden to use Teach Pendant in the high dust concentration and high grease concentration environment since its protection rating is IP20.
- ❖ To ensure the Teach Pendant functions normally, any impact and fall are forbidden.



**Names and functions on Teach Pendant**

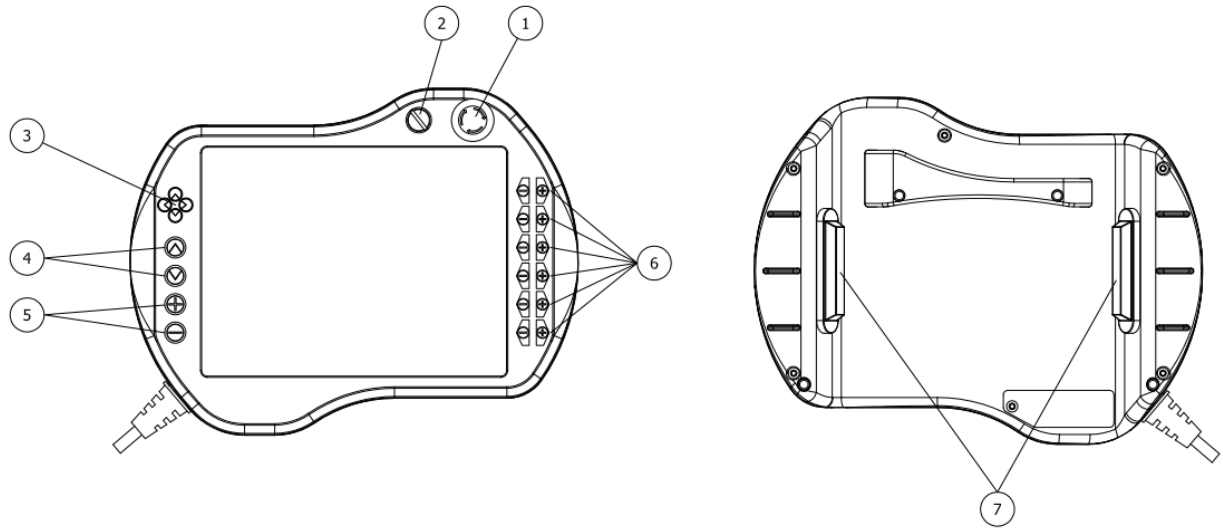

**Button Definition:**

No.	Item	Function Description
1	Emergency Stop Switch	Disable servo and directly stop the robot.
2	Mode Switch	Switch mode among Manu, Auto and Lock
3	XY-Axis T1 Key	In the T1 mode, control the movement in XY-axis.
4	Z-Axis T1 Key	In the T1 mode, control the movement in Z-axis.
5	Speed Key	Adjust the robot speed
6	T1 Key	Adjust the value in each axis in the different mode.
7	Enable Switch <sup>(Note 1)</sup>	When pressing one of the switches, the robot can start to move; the robot will stop directly when releasing this switch or pressing it to the end.

\*Note 1: instruction on enable switch:

In T1 and T2 mode, the enable switch must be held at center position to start the robot. In Auto mode (AUT) and External Auto mode (EXT), the enable switch should be held at center position only in the moment it starts, and then release.

The Enable Switch has three positions:

- (1) Not pressed → The robot can't move.
- (2) Center position → The robot can move and teach
- (3) Fully pressed → The robot can't move.

In addition, the enable switch on both side has the same function.

## 5. Maintenance

### 5.1 UPS Battery (Only For Non-CE Version)

The controller contains a battery, the battery is charged as:

- (1) When first time power-on, the battery needs to be charged greater than 4HR.  
(Manipulator can be performed simultaneously)
- (2) When it is in a low battery state (the UPS will produce around 2~3 beep sound for 1 second), the controller should be switched on more than 4HR for charging UPS.
- (3) If the controller is idle for more than one month, please charge it more than 4HR

When the voltage of UPS is too low (lower than 10.2V) or due to malfunction causing the controller unable to reboot, please replace the battery. (Refer to CH1.3 standard and optional equipment or could self-purchase from local battery dealer: model NPH5-12)

Note 1: If battery failed during warranty period, free replacement of battery will be provided.

Note 2: Starting from 15<sup>th</sup> month once the controller is started using, the battery voltage should be measured every month using multimeter in order to make sure the battery quality, if voltage lower than 10.2V, please replace the battery. Measured point is shown below.

Procedure for replacing UPS battery is shown as follows:

- (1) Remove 11 pieces of M4X0.7PX12L Phillips screws on the cover and remove the cover.
- (2) The battery is located on the right side in the cabinet. Remove the power cable connected to the battery.
- (3) Remove the Volero which fixes the battery; then take out and replace the battery.
- (4) After ensuring the battery is fixed, connect it with the power cable. Install the cover in order, after confirming that all the cables are connected securely.

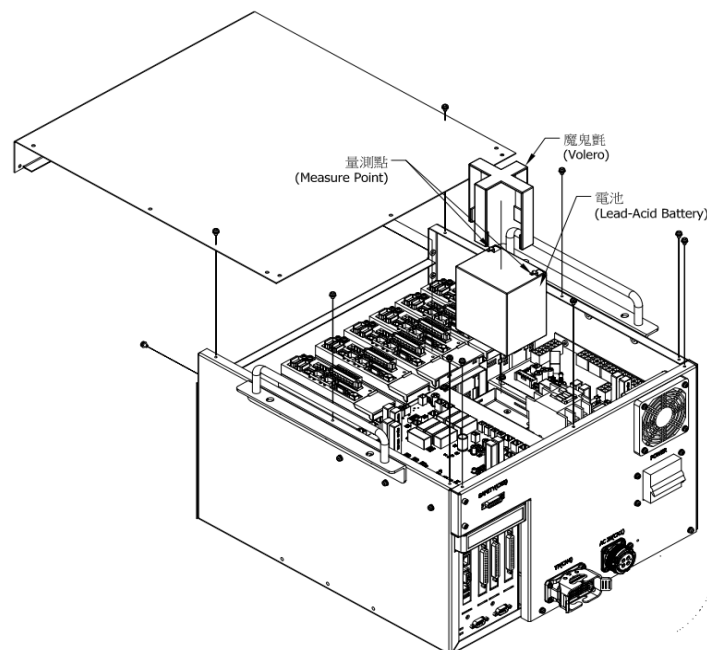



**CAUTION**

- ❖ After replacement, please ensure the polarities of battery and power cable are connected correctly; positive (red) to positive and negative (black) to negative.
- ❖ The controller contains lead-acid battery. It may cause the lack of electricity by natural wearing and will not be able to be turned on successfully. If it is idle for a long time, please maintain the power transmission at least every 3 months and keep it on lasting for 24 hours. Or take out the battery and keep the voltage of the battery over 13V.
- ❖ When the voltage of the battery is too low causing failure to turn on the controller, please take out the battery and charge it with the external power source until the voltage is over 13V. Or replace the battery with a new one and then try to turn it on again.
- ❖ Flipping it 90 degrees on the side or turning it over 180 degrees are forbidden while installing the controller. This is to protect the internal battery component.

## 5.2 Fan Cotton Filter

Every air inlet outside the cabinet contains cotton filter, which has the function of blocking external foreign matter, enhancing the air convection and aid heat dissipation. Please decide the frequency of cotton filter replacement according to working environment.

- (1) Remove M4X0.7PX12L Phillips screws on the cover.
- (2) Replace internal cotton filter.
- (3) Install the cover in order.

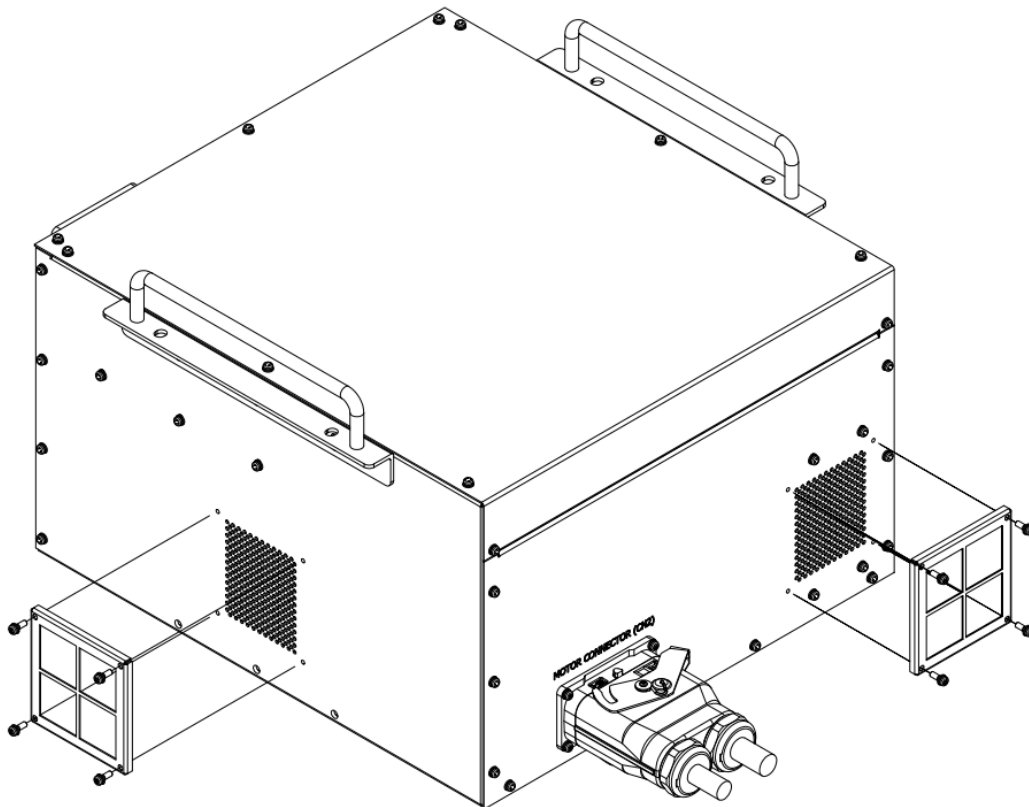

### CAUTION

- ❖ The accumulation of foreign matter causing internal cotton filter experiencing poor convection. It may cause the internal occurring over-temperature and crash.

### 5.3 Fuse

If encountered the following two situations, please try to open the controller cover and check whether the internal fuse has melted:

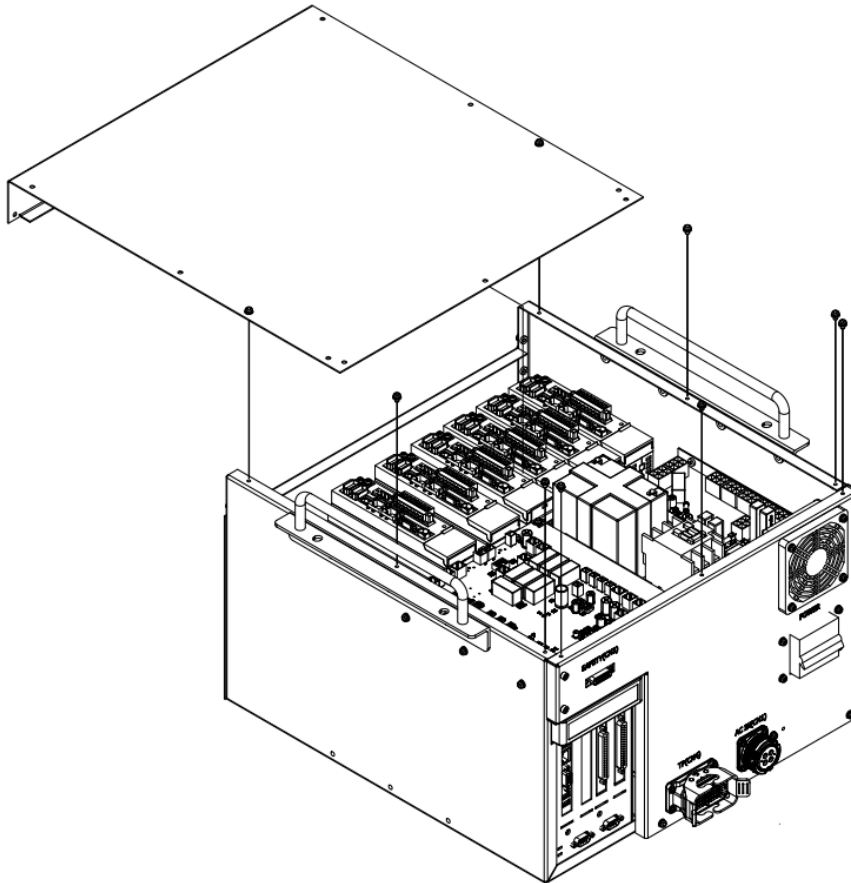

1. If unable to start the controller, please follow the steps below to replace the fuse:
  - (1) Remove 11 pieces of M4X0.7PX12L Phillips screws on the cover and remove the cover.
  - (2) Check FUSE1, FUSE2, FUSE3 on RCBCDZ023.
  - (3) Remove the protective cover of the fuse, if the fuse is melted, replace a new fuse.
  - (4) The specification of FUSE1, FUSE2, FUSE3 are 15A 5\*20mm glass fuse.
  - (5) After replacing a new fuse, cover the fuse with protective cover.
  - (6) Check FUSE1 on RCBCDZ033, if the fuse is melted, please replace a new fuse LITTELFUSE 0297005 5A
  - (7) Close the cover and secure the screws.



**CAUTION**

- ❖ When replacing the fuse, it should be replaced straight up and down, and should not over expanded the shrapnel.
- ❖ Before installation, please press the shrapnel inwards gently to keep the distance between the top ends of the shrapnel slightly less than 5mm, and then install the fuse.
- ❖ After the fuse is replaced, it is recommended that the customer use a multimeter to measure (The both ends of the solder joint of the fuse base has a resistance value less than  $0.5\Omega$ )

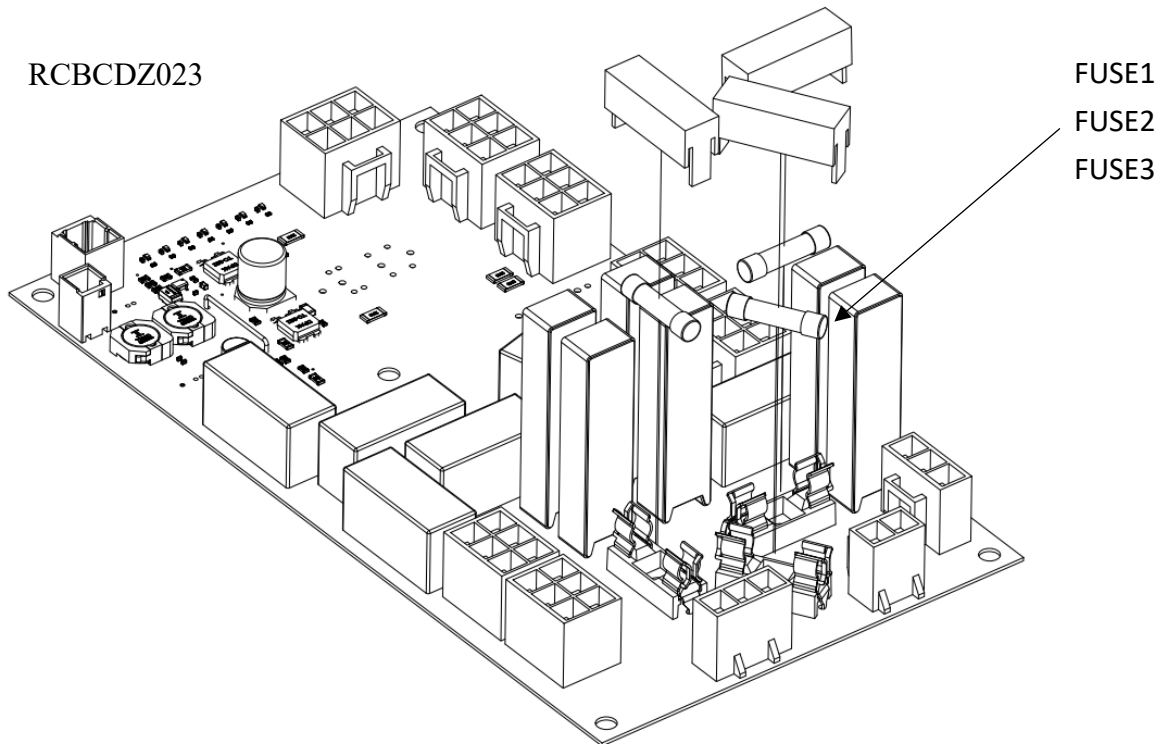

2. If abnormal sound is produced during the operation of the arm or an error code 02-02-11 appeared during automatic running
  - (1) Remove 11 pieces of M4X0.7PX12L Phillips screws on the cover and remove the cover.
  - (2) Check FUSE5 on RCBCDZ033, if the fuse is melted, please replace a new fuse LITTELFUSE 0297002 2A (HIWIN Part No.: 46210052)
  - (3) Close the cover and secure the screws.

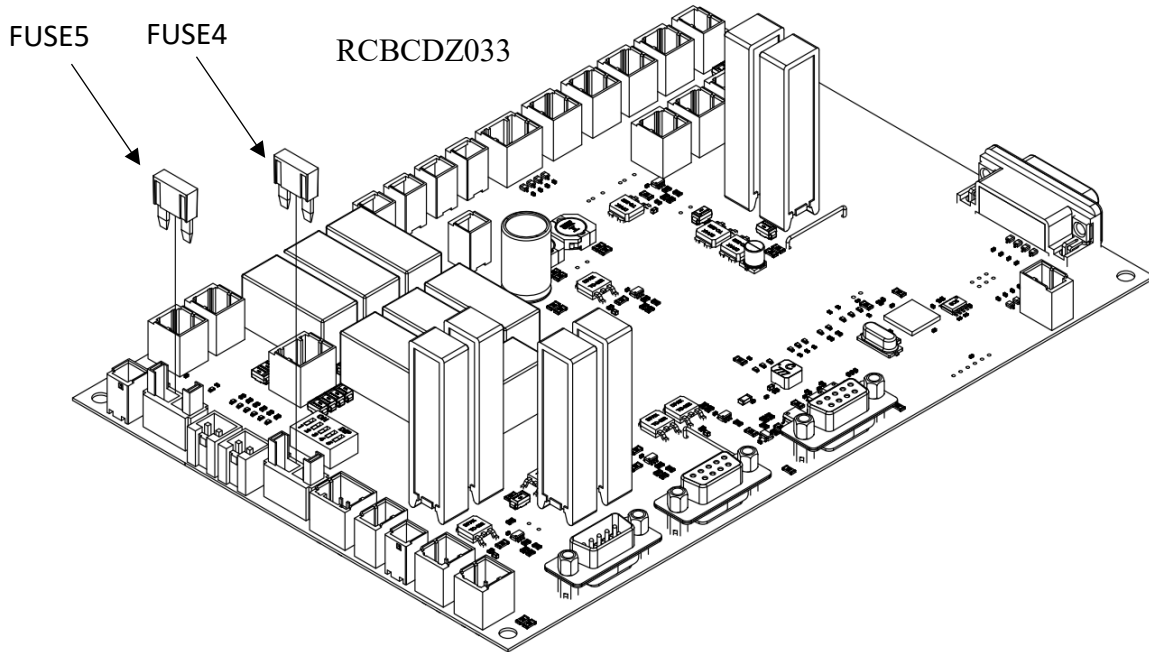

**WARNING**

- ❖ Make sure the controller is disconnected to the power supply before replacing the fuse.
- ❖ Replacing fuses with different ampere or other conductive materials (Iron wire, Iron sheet) are forbidden.

## **Articulated Robot Controller - GB Series** (Original Instruction) **User Manual**

Publication Date : November 2018, first edition

- 
1. HIWIN is a registered trademark of HIWIN Technologies Corp. For your protection, avoid buying counterfeit products from unknown sources.
  2. Actual products may differ from specifications and photos provided in this catalog. These differences may be the result of various factors including product improvements.
  3. HIWIN will not sell or export products or processes restricted under the "Foreign Trade Act" or related regulations. Export of restricted products should be approved by proper authorities in accordance with relevant laws and shall not be used to manufacture or develop nuclear, biochemical, missiles or other weapons.
  4. HIWIN website for patented product directory: [http://www.hiwin.tw/Products/Products\\_patents.aspx](http://www.hiwin.tw/Products/Products_patents.aspx)





## Subsidiaries / Research Center

HIWIN GmbH  
OFFENBURG, GERMANY  
[www.hiwin.de](http://www.hiwin.de)  
[www.hiwin.eu](http://www.hiwin.eu)  
[info@hiwin.de](mailto:info@hiwin.de)

HIWIN JAPAN  
KOBE · TOKYO · NAGOYA · NAGANO ·  
TOHOKU · SHIZUOKA · HOKURIKU ·  
HIROSHIMA · FUKUOKA · KUMAMOTO,  
JAPAN  
[www.hiwin.co.jp](http://www.hiwin.co.jp)  
[info@hiwin.co.jp](mailto:info@hiwin.co.jp)

HIWIN USA  
CHICAGO, U.S.A.  
[www.hiwin.com](http://www.hiwin.com)  
[info@hiwin.com](mailto:info@hiwin.com)

HIWIN Srl  
BRUGHERIO, ITALY  
[www.hiwin.it](http://www.hiwin.it)  
[info@hiwin.it](mailto:info@hiwin.it)

HIWIN Schweiz GmbH  
JONA, SWITZERLAND  
[www.hiwin.ch](http://www.hiwin.ch)  
[info@hiwin.ch](mailto:info@hiwin.ch)

HIWIN s.r.o.  
BRNO, CZECH REPUBLIC  
[www.hiwin.cz](http://www.hiwin.cz)  
[info@hiwin.cz](mailto:info@hiwin.cz)

HIWIN SINGAPORE  
SINGAPORE  
[www.hiwin.sg](http://www.hiwin.sg)  
[info@hiwin.sg](mailto:info@hiwin.sg)

HIWIN KOREA  
SUWON · MASAN, KOREA  
[www.hiwin.kr](http://www.hiwin.kr)  
[info@hiwin.kr](mailto:info@hiwin.kr)

HIWIN CHINA  
SUZHOU, CHINA  
[www.hiwin.cn](http://www.hiwin.cn)  
[info@hiwin.cn](mailto:info@hiwin.cn)

Mega-Fabs Motion System, Ltd.  
HAIFA, ISRAEL  
[www.mega-fabs.com](http://www.mega-fabs.com)  
[info@mega-fabs.com](mailto:info@mega-fabs.com)

## HIWIN TECHNOLOGIES CORP.

No. 7, Jingke Road,  
Taichung Precision Machinery Park,  
Taichung 40852, Taiwan  
Tel: +886-4-23594510  
Fax: +886-4-23594420  
[www.hiwin.tw](http://www.hiwin.tw)  
[business@hiwin.tw](mailto:business@hiwin.tw)